

**SINGER**  
**47W11**

# LIST OF PARTS



## MACHINE No. 47w11

THE SINGER MANUFACTURING COMPANY

## INDEX

---

	PAGE
ACCESSORIES .....	15
BINDERS .....	22
BORBIN WINDER .....	15
FEED DOGS .....	17
FOOT LIFTER .....	16
MACHINE No. 47w11 .....	7
NUMERICAL LIST OF PARTS .....	27
OBSOLETE PARTS .....	24
PRESSER FEET .....	17
THROAT PLATES .....	21

From the library of: Diamond Needle Corp

# Instructions for Ordering

In ordering from this list, use **ONLY** the **PART** number in the **FIRST** column.

The number stamped on a Sewing Machine Part is the number of the Single Part only, except when the part includes Set Screws, Clamping Screws, Studs and Rollers Spun on, Small Wires riveted, or Parts soldered together, etc., which it is necessary to furnish in combination.

Every combination of parts sent out has its specific number which, although not stamped on Parts (except in above cases) must be used when ordering the combination.

Each number always indicates the **SAME PART** in whatever list it appears, or for whatever Machine.

The letters after some of the numbers indicate the style of finish only, as follows:

- A. Hardened, Polished and Plated.
- B. Polished and Plated.
- C. Hardened only.
- D. Polished only.
- E. Soft, not polished.
- F. Hardened and Polished.
- H. Blued.

These letters **MUST BE USED** when they appear in the list and **AFTER** the number, as in the list.

In this series

- 200001 to 201500 are Screw Numbers.
- 201501 to 201800 are Nut Numbers.
- 201801 to 202000 are Roller Numbers.
- 202001 and upward are numbers of Machine Parts.

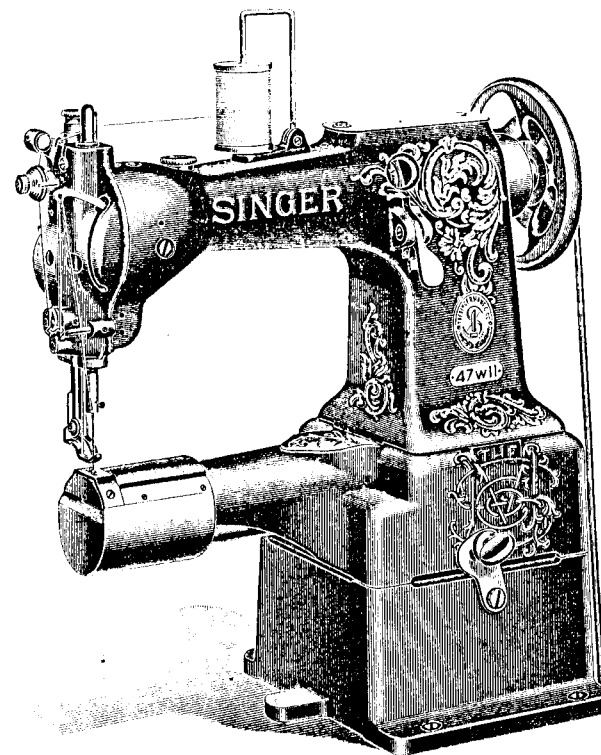
The figures in the second column refer only to the plate in which the illustration of the part is shown and are **NOT TO BE USED** in ordering.

Two or more numbers over a cut indicate that the difference between such parts is not visible in an illustration.

Parts marked with an asterisk (\*) are furnished only when repairs are made at the factory.

## LIST OF PARTS COMPLETE

FOR



From the library of: Diamond Needle Corp

## MACHINE No. 47w11

DROP FEED. CYLINDER BED. ALTERNATING

PRESSERS

For Tailoring

No.	Plate	Name
*215766	---	Arm .....
213144	11150	" Cap .....
200278H	12311	" " Screw .....
202248H	11151	" " Washer .....
204235	12481	" Position Pin .....
200963E	12311	" Screw (3) .....

No.	Plate	Name
202005	11151	Arm Screw Washer (3) .....
213366	12482	" Shaft .....
213602	—	" " 213366 with 200244b, 200245b, 213349 to 213351, 213354, 213654, 213655 and two 201528e
204801	11150	Arm Shaft Bushing (back) with 202260 .....
202260	—	Arm Shaft Bushing (back) Oil Packing (wick) .....
200338c	11151	Arm Shaft Bushing (back) Set Screw .....
213299	11150	Arm Shaft Bushing (center) with 202260 .....
202260	—	Arm Shaft Bushing (center) Oil Packing (wick) .....
200341c	11151	Arm Shaft Bushing (center) Set Screw .....
213781	12483	Arm Shaft Bushing (front) with 202036 and 202260 .....
202260	—	Arm Shaft Bushing (front) Oil Packing (wick) .....
200502b	11151	Arm Shaft Bushing (front) Oil Packing Thumb Screw .....
202036	12481	Arm Shaft Bushing (front) Posi- tion Pin .....
200352c	11151	Arm Shaft Bushing (front) Set Screw .....
204804	12482	Arm Shaft Connection with four 200054E (2) .....
200054E	11151	Arm Shaft Connection Screw .....
204805	12482	Balance Wheel, 5½ in. diam. (belt groove 2¾ in. diam.), with 200328c and 200335c .....
200062h	12311	Balance Wheel Adjusting Screw ..
200328c	12311	" " Position Screw .....
200335c	12311	" " Set Screw .....
*213369	—	Bed (cylinder) with 200439c, 213314, 213380 and two 200516E .....
213786	11150	Bed (cylinder) Cap .....
200574d	12481	" " " Screw (2) .....
213787	11150	" " End Cover .....
213353	—	" " Base (high) .....
213890	—	" " (low) .....
		Note: High Bed Base 213353 furnished only when ordered.
203184	11060	Bed Clamp .....
200262h	11060	" " Hinge Screw .....
202622	11151	" " Packing Washer .....
200728B	11060	" " Thumb Screw .....

No.	Plate	Name
203185	11060	Bed Clamp Washer .....
202618	13482	" Hinge .....
200030h	12473	" " Screw (6) .....
213338	11150	" Slide (back) .....
213685	12481	" " Clamp Plate .....
215781	—	" " " " .....
200582h	11151	" " " " Screw (4) ..
200459d	12481	" " " " Thumb Screw
226071	12481	" " " " " "
		Spring Washer .....
<del>233939</del> (203208)	11228	Bobbin .....
203210	11228	" Case Base with 202056, 203211 to 203213 and 203216 .....
203211	11151	Bobbin Case Base Latch .....
*202056	—	" " " " Pin .....
203212	11151	" " " " Plunger ..
203213	11151	" " " " Spring .....
203209	11228	" " Cap with 200984c, 203214, 203215 and two 200594c .....
203214	11228	Bobbin Case Tension Spring .....
200984c	11151	" " " " Regu- lating Screw .....
200594c	11228	Bobbin Case Tension Screw .....
203215	11228	" " Thread Guide .....
200594c	11228	" " " " Screw ..
203216	11228	" " Washer (cloth) .....
203217	11228	Bobbin Case complete, Nos. 203209 and 203210 .....
204473	12482	Face Plate with 200366h, 200368h, 200685E, 202087, 202090, 204185, 204281 and two 200397h .....
200053c	12311	Face Plate Screw .....
204185	11151	" " Thread Guide .....
200397h	11151	" " " " Set Screw
204474	12482	Face Plate complete, Nos. 200309E, 200577h, 202088, 204059, 204272, 204280, 204473 and 204486 .....
213295	11060	Feed Bar with 200544E and 213610
213298	12481	" " Connecting Link with two 200072c .....
200072c	11151	Feed Bar Connecting Link Pinch Screw .....
200935E	11151	Feed Bar Connecting Link Screw Stud .....
201532E	11151	Feed Bar Connecting Link Screw Stud Nut .....
213610	11151	Feed Bar Connecting Link Stud ..
212281	12177	" Dog .....

No.	Plate	Name
200544E	12481	Feed Dog Screw .....
213349	12483	" Driving Eccentric (adjustable)
213350	12483	" " " Adjusting Disc
213351	12483	" " " Flange with 200378c and 200437c .....
200437c	12311	Feed Driving Eccentric Flange Position Screw .....
200378c	12311	Feed Driving Eccentric Flange Set Screw .....
213655	11151	Feed Driving Eccentric Friction Spring Washer .....
200245D	11151	Feed Driving Eccentric Friction Spring Washer Screw .....
201528E	11151	Feed Driving Eccentric Friction Spring Washer Screw Nut .....
200244D	11151	Feed Driving Eccentric Fulcrum Screw .....
201528E	11151	Feed Driving Eccentric Fulcrum Screw Nut .....
213300	12482	Feed Driving Rock Shaft .....
213302	—	" " " " 213300 with 200583u, 200935E, 201532E, 213295, 213296, 213298 and 213748
203244	11151	Feed Driving Rock Shaft Collar with two 200393c .....
200393c	11151	Feed Driving Rock Shaft Collar Set Screw .....
213354	12482	Feed Driving Rock Shaft Connection with 200054E and 202277 ...
213654	11151	Feed Driving Rock Shaft Connection Collar .....
200919c	11060	Feed Driving Rock Shaft Connection Hinge Screw .....
201522E	11151	Feed Driving Rock Shaft Connection Hinge Screw Nut .....
202277	—	Feed Driving Rock Shaft Connection Oil Packing (wick) .....
200054E	11151	Feed Driving Rock Shaft Connection Pinch Screw .....
213301	11060	Feed Driving Rock Shaft Crank with 200050c .....
200050c	12481	Feed Driving Rock Shaft Crank Pinch Screw .....
213296	12473	Feed Lifting Cam with 200392c and 200447c .....
200447c	11151	Feed Lifting Cam Position Screw
213748	12473	" " " Retainer .....
200583u	11151	" " " " Screw ..

No.	Plate	Name
200392c	12481	Feed Lifting Cam Set Screw .....
213161	12473	" Regulating Lever with 213657
200665c	11151	" " " Hinge Screw
213656	11151	" " " Spring .....
213657	—	" " " " Pin ..
227461	12482	Foot Lifter Lifting Lever .....
227789	—	" " " " 227461 with 200262u .....
200262u	11060	Foot Lifter Lifting Lever Hinge Screw .....
221145	12481	Foot Lifter Lifting Lever Position Spring (right) .....
200835D	12481	Foot Lifter Lifting Lever Position Spring Screw .....
*203239	—	Hook (sewing) .....
203240	11228	" 203239 with 201253E, 201376E and 203251 .....
203290	11228	Hook and Bobbin Case complete, Nos. 203217 and 203240 .....
203549	11254	Hook Bevel Gear Socket, 18 teeth
200556u	12473	" " " " Screw ...
213319	12473	" " Pinion with two 200386c
200386c	11151	" " " Set Screw .....
221171	12482	" Driving Shaft .....
213314	11150	" " " Bearing .....
202126	11151	" " " " Position Pin (2) .....
200516E	12311	Hook Driving Shaft Bearing Screw
213380	11151	" " " Bushing .....
200439c	12311	" " " " Position Screw .....
204246	12473	Hook Driving Shaft Collar (back) with two 200383c .....
200383c	12311	Hook Driving Shaft Collar (back) Set Screw .....
203244	11151	Hook Driving Shaft Collar (front) with two 200393c .....
200393c	11151	Hook Driving Shaft Collar (front) Set Screw .....
203251	11228	Hook Gib .....
201376E	12481	" " Hinge Screw .....
201253E	12481	" " Screw .....
203552	11254	" Saddle (right) with 202299 ..
202299	—	" " Oil Packing (wick) ...
200541E	12473	" " Screw (2) .....
225837	11151	" " " Washer (2) ....
203254	11228	" Washer .....
203554	11254	Hook Saddle (right) complete, Nos. 200556u, 203254, 203290, 203549 and 203552 .....

No.	Plate	Name
204475	10483	Lifting Lever with 200122H .....
208389	—	“ “ 204475 with 200935F, 201534E, 204478 and 206659 ....
213004	12473	Lifting Lever Driving Crank .....
204478	10483	“ “ “ “ Link
200122H	10483	“ “ “ “ “
		Stop Screw .....
200400C	12473	Lifting Lever Driving Crank Position Screw .....
200387C	12376	Lifting Lever Driving Crank Position Screw Set Screw .....
204479	12473	Lifting Lever Driving Crank Position Screw Set Screw Packing (brass) .....
200181D	10483	Lifting Lever Stop Screw .....
204480	10483	“ “ Stud Lifting Bracket with 200086C and 200181D .....
208390	—	Lifting Lever Stud Lifting Bracket 204480 with 208389 .....
200086C	12481	Lifting Lever Stud Lifting Bracket Pinch Screw .....
229626	13037	Lifting Presser Foot .....
200074F	12481	“ “ “ Screw .....
204483	12483	Needle Bar (hollow) with 200125F, 200587E and 204487 .....
204418	—	Needle Bar Connecting Link .....
204249	12481	“ “ “ Stud with 200072C and 202277 .....
202277	—	Needle Bar Connecting Stud Oil Packing (wick) .....
200072C	11151	Needle Bar Connecting Stud Pinch Screw .....
204326	—	Needle Bar Packing Cord (2) .....
200504E	12481	“ “ Screw Bushing (lower)
200503B	12481	“ “ “ “ (upper) ..
204487	10483	“ “ Thread Guide .....
200587E	10483	“ “ “ Screw ...
200125F	12481	“ Set Screw .....
204251	12483	Presser Bar (hollow) with 200074F
204252	12481	“ “ Lifter .....
200550C	12311	“ “ “ Hinge Screw ..
204481	12473	“ “ Lifting Bracket Position Guide .....
200362C	12311	Presser Bar Lifting Bracket Position Guide Set Screw .....
204327	—	Presser Bar Packing Washer (felt)
200504E	12481	“ “ Screw Bushing (lower)
204482	12473	“ “ Spring .....

No.	Plate	Name
200491R	12481	Presser Bar Thumb Screw (pressure regulating) .....
201506B	12376	Presser Bar Thumb Screw Check Nut .....
202068	12483	Spool Holder Base .....
200575H	12311	“ “ “ Screw .....
204296	12483	“ “ Wire .....
200079H	12311	“ “ “ Hinge Screw ...
204297	12483	Spool Holder complete, Nos. 200079H, 202068 and 204296 .....
213925	12483	Take-up Cam with 200347C, 200383C, 200387C, 200400C, 200430C and 204479 .....
203172	10445	Take-up Cam Friction Washer ...
200430C	12311	“ “ Position Screw ...
200383C	12311	“ “ “ “ Check Screw .....
200347C	12376	Take-up Cam Set Screw .....
213005	12483	Take-up Cam complete, Nos. 204416, 213004 and 213925 .....
204262	10445	Take-up Lever .....
206556	—	“ “ 204262 with 204263 ..
204263	10445	“ “ Bearing with 204264
204264	10445	“ “ “ Position Pin ..
200042F	12311	“ “ “ Screw .....
201816	10445	“ “ Roller .....
204266	10445	Take-up Lever complete, Nos. 200042F, 201816 and 206556 .....
202402	12309	Tension Disc .....
202090	12309	“ “ Position Pin .....
204486	10483	“ Release Lever .....
200685E	10483	“ “ “ Position Screw
200309E	10483	“ “ “ Screw .....
202075	12309	“ “ Plunger .....
204416	12481	“ “ Slide with 204269 ...
204269	12481	“ “ “ Spring .....
202407	10881	“ Spring .....
200632B	12309	“ Stud .....
200397H	11151	“ Stud Set Screw .....
201572B	10881	“ Thumb Nut .....
204271	12309	“ Washer .....
204272	12309	Tension complete, Nos. 200632B, 201572B, 202075, 202407, 204271 and two 202402 .....
204274	12309	Thread Controller Plate .....
200577H	12311	“ “ “ Screw ...
202098	12309	“ “ Roller .....
204275	12309	“ “ “ Guard .....
202084	12309	“ “ “ “ Washer

No.	Plate	Name
200300c	12309	Thread Controller Roller Screw ...
204276	12309	" " Spring .....
204333	12309	" " " Guard .....
200581H	12309	" " " " Screw
202087	12473	" " " Stop .....
202088	10483	" " " Stud with 204925 .....
200366H	12309	Thread Controller Spring Stud Set Screw .....
204925	12481	Thread Controller Spring Stud Washer .....
205987	12309	Thread Controller complete, Nos. 200300c, 200581H, 202084, 202098, 204274, 204275 and 204333 .....
204280	12309	Thread Controller and Spring com- plete, Nos. 204276 and 205987 ..
202413	12481	Thread Guide .....
204281	12309	" Retainer Guide Wire .....
202091	12309	" " Sleeve .....
202092	12309	" " Spring .....
204058	12309	" " Stud .....
200368H	12309	" " " Set Screw ....
204059	12309	Thread Retainer complete, Nos. 202091, 202092 and 204058 .....
212280	12177	Throat Plate, 46 needle hole, for needle sizes 16 and 18 .....
200577H	12311	Throat Plate Screw (2) .....
206660	—	Vibrating Presser Bar .....
206659	12376	" " " " 206660 with 204493 and two 200138D .....
200935F	11151	Vibrating Presser Bar Hinge Screw
201534E	12481	" " " " " " Nut .....
229838	12376	Vibrating Presser Bar Position Stop
200053C	12311	" " " " " " Screw .....
204493	12376	Vibrating Presser Bar Spring .....
200138D	12473	" " " " " Screw
204620	12376	" " Foot .....
200098F	12473	" " " Screw .....
203357	12473	" " " " Washer

## ACCESSORIES

No.	Plate	Name
203208	11228	Bobbin (5) .....
*225482	—	" Case Screw Driver Blade ...
*225483	—	" " " " Handle ..
225497	11156	Bobbin Case Screw Driver com- plete, Nos. 225482 and 225483 ...
204033	11150	Wrench .....
126 x 3	—	Needles, two each, sizes 16, 18 and 20 .....
227104	—	Drip Pan with one wood screw 1½ in., No. 14 .....
41401	11156	Machine Rest Pin (wood) .....
36578	11156	Oiler with 36579 .....
36579	11156	" Spout, 3½ in. long, with 120117
120117	—	" " Washer .....
*225484	—	Screw Driver Blade .....
*225485	—	" " Handle .....
225498	11156	Screw Driver complete (7¼ in. long), Nos. 225484 and 225485 ..
225554	11156	Wrench (steel) .....
225487	12484	Roller Presser Hinge Screw Nut Wrench .....

**BOBBIN WINDER**

**Swing Automatic, Right Hand**

*225451	—	Bobbin Holder .....
225453	10882	Frame with 202277 and 225438 ....
225454	10882	" Hinge Pin .....
202277	—	" Oil Packing (wick) .....
225438	10882	" " Well Cap .....
225455	10882	" Spring .....
225456	10882	" " Plunger .....
202473	10883	Pulley with 200380c .....
200380c	12319	" Set Screw .....
*225443	—	Spindle .....
225452	10882	" 225443 with 225451 .....
225444	10882	Stop Latch .....
200056E	10882	" " Screw .....
225458	10882	" " Thumb Lever .....
225459	10882	" " " " Hinge Stud
225460	10882	" " " " Joint Stud
202478	10882	" " Trip Lever .....
200299H	10882	" " " " Hinge Screw

No.	Plate	Name
225461	10881	Tension Bracket with 201499B . . . .
200082D	10881	" " " Screw . . . . .
202104	10881	" " " Washer . . . . .
2102	10881	" Disc . . . . .
202407	10881	" Spring . . . . .
201499B	10881	" Stud . . . . .
201572B	10881	" " Thumb Nut . . . . .
225462	10881	Bobbin Winder Tension Bracket complete, Nos. 201572B, 202407, 225461 and two 2102 . . . . .
225463	10883	Bobbin Winder and Tension Bracket Base . . . . .
225436	10883	Universal Bobbin Winder complete, Nos. 200056E, 200082D, 200299H, 202104, 202473, 202478, 225444, 225452 to 225456, 225458 to 225460, 225462, 225463 and two wood screws $\frac{3}{4}$ in., No. 13, R.H.B. . . . .

#### FOOT LIFTER

227952	11156	Foot Lifter Lever with 227954 . . . .
227678	11156	" " " Chain, 48 in. long, with 202784 . . . . .
227954	12484	Foot Lifter Lever Chain Hook (lower) . . . . .
202784	12484	Foot Lifter Lever Chain Hook (upper) . . . . .
225016	12484	Foot Lifter Lever Hinge Pin . . . . .
227953	11156	" " " Stand with two wood screws 1 in., No. 13 . . . . .
227955	11156	Foot Lifter Lever complete, Nos. 225016, 227678, 227952 and 227953 (Other Foot Lifter Parts are listed with Parts of machine head.)

## FEED DOGS

No.	Plate	Name
212285	12485	Feed Dog, for 221183 . . . . .
212258	12485	" " " 212256 and 212257 . .
212281	12177	" " " 212279 and 212280 . .
212282	12177	" " " 212279 and 212280 . .
212290	12179	" " " 212288 and 212289 . .
212220	12485	" " " 212291 to 212296 . . .
212221	12485	" " " 212291 to 212296 . . .
212298	12485	" " " 212297 . . . . .

## PRESSER FEET

204601	13034	Lifting Presser Foot, for 206707 and 206716 . . . . .
204602	13034	Lifting Presser Foot, for 206672, 206673, 206707 and 206715 to 206717 . . . . .
204603	13034	Lifting Presser Foot, for 206672, 206673, 206707 and 206715 to 206717 . . . . .
204604	13034	Lifting Presser Foot, for 206668, 206675, 206678, 206714 and 206719
204605	13034	Lifting Presser Foot, for 206668, 206675, 206678, 206714 and 206719
204606	13034	Lifting Presser Foot, for 206676, 206699 and 206700 . . . . .
204607	13034	Lifting Presser Foot, for 206707 and 206716 . . . . .
204609	13034	Lifting Presser Foot, for 206672, 206673, 206681, 206707 and 206715 to 206717 . . . . .



## Presser Feet

No.	Plate	Name
204610	13035	Lifting Presser Foot, for 206676, 206699 and 206700 .....
204595	12376	Lifting Presser Foot, for 204620 ..
204611	13035	" " " " 204620, 204634, 206698, 206705, 206706 and 229620 .....
204612	13035	Lifting Presser Foot, for 204620, 204634, 206698, 206705, 206706 and 229620 .....
206674	13035	Lifting Presser Foot, 46 needle hole, for 206668, 206675, 206678, 206714 and 206719 .....
221182	13035	Lifting Presser Foot, for 204620, 204634, 206698 and 229620, for use with 230656 .....
206697	13035	Lifting Presser Foot, for 204620, 204634, 206698, 206701 and 229620 .....
229625	13035	Lifting Presser Foot, for 204620, 204634, 206698, 206705, 206706 and 229620 .....
229633	13035	Lifting Presser Foot, for 206672, 206673, 206707 and 206715 to 206717 .....
206695	13037	Lifting Presser Foot, for 204620, 204634, 206698 and 229620 .....
206694	13037	Lifting Presser Foot, for 204621, 206692 and 206693 .....
204640	13037	Lifting Presser Foot, for 204620, 204634, 206698 and 229620 .....
229626	13037	Lifting Presser Foot, for 204620, 204634, 206698 and 229620 .....
206662	13037	Lifting Presser Foot, 46 needle hole, for 206663 .....
206664	13037	Lifting Presser Foot (grooved), 46 needle hole, for heavy cording, for 206665 .....
206696	13037	Lifting Presser Foot, 46 needle hole, for 204620, 204634, 206698 and 229620 .....
229628	13037	Lifting Presser Foot, for 204621, 206692 and 206693 .....
229629	13037	Lifting Presser Foot, for 206691 and 229630 .....
206702	13035	Lifting Presser Foot, for 206703 and 206704 .....
204634	13036	Lifting Presser Foot, for 204611, 204612, 204640, 206695 to 206697, 221182, 229625 and 229626 .....

## Presser Feet

No.	Plate	Name
206663	13036	Vibrating Presser Foot, for 206662
206678	13036	" " " " 204604, 204605 and 206674 .....
206672	13036	Vibrating Presser Foot, for 204602, 204603, 204609 and 229633 .....
206673	13036	Vibrating Presser Foot, for 204602, 204603, 204609 and 229633 .....
206675	13036	Vibrating Presser Foot, for 204604, 204605 and 206674 .....
206691	13036	Vibrating Presser Foot, for 229629
206692	13036	" " " " 206694 and 229628 .....
206700	13036	Vibrating Presser Foot, for 204606 and 204610 .....
206703	13036	Vibrating Presser Foot, for 206702
206705	13036	" " " " 204611, 204612 and 229625 .....
206706	13036	Vibrating Presser Foot, for 204611, 204612 and 229625 .....
206714	13036	Vibrating Presser Foot, for 204604, 204605 and 206674 .....
206719	13036	Vibrating Presser Foot, for 204604, 204605 and 206674 .....
206698	13036	Vibrating Presser Foot, for 204611, 204612, 204640, 206695 to 206697, 221182, 229625 and 229626 .....
229630	13036	Vibrating Presser Foot, for 229629
204621	13038	" " " " 206694 and 229628 .....
229620	13038	Vibrating Presser Foot, for 204611, 204612, 204640, 206695 to 206697, 221182, 229625 and 229626 .....
206704	13038	Vibrating Presser Foot, for 206702
206701	13038	" " " " bind- ing slippers, for 206697 .....
206716	13038	Vibrating Presser Foot, for 204601 to 204603, 204607, 204609 and 229633 .....
206665	13038	Vibrating Presser Foot, for 206664
206668	13038	" " " " 204604, 204605 and 206674 .....
206681	13038	Vibrating Presser Foot, for 204609
206676	13038	" " " " 204606 and 204610 .....
206715	13038	Vibrating Presser Foot, for 204602, 204603, 204609 and 229633 .....
206699	13038	Vibrating Presser Foot, for 204606 and 204610 .....

No.	Plate	Name
206707	13038	Vibrating Presser Foot, for 204601 to 204603, 204607, 204609 and 229633 .....
206693	13038	Vibrating Presser Foot, for 206694 and 229628 .....
206717	13038	Vibrating Presser Foot, for 204602, 204603, 204609 and 229633 .....
204620	12376	Vibrating Presser Foot, for 204595, 204611, 204612, 204640, 206695 to 206697, 221182, 229625 and 229626

## THROAT PLATES

No.	Plate	Name
212256	12485	Throat Plate, 50 needle hole, for needle sizes 14 and 15, for 212258
212257	12485	Throat Plate, 46 needle hole, for needle sizes 16 and 18, for 212258
212279	12177	Throat Plate, 50 needle hole, for needle sizes 14 and 15, for 212281 and 212282 .....
212280	12177	Throat Plate, 46 needle hole, for needle sizes 16 and 18, for 212281 and 212282 .....
212288	12179	Throat Plate, 50 needle hole, for needle sizes 14 and 15, for 212290
212289	12179	Throat Plate, 46 needle hole, for needle sizes 16 and 18, for 212290
212291	12179	Throat Plate, 50 needle hole, for needle sizes 14 and 15, for 212220 and 212221 .....
212292	12179	Throat Plate, 46 needle hole, for needle sizes 16 and 18, for 212220 and 212221 .....
212293	12179	Throat Plate, 50 needle hole, for needle sizes 14 and 15, for 212220 and 212221 .....
212294	12179	Throat Plate, 46 needle hole, for needle sizes 16 and 18, for 212220 and 212221 .....
212295	12179	Throat Plate, 50 needle hole, for needle sizes 14 and 15, for 212220 and 212221 .....
212296	12179	Throat Plate, 46 needle hole, for needle sizes 16 and 18, for 212220 and 212221 .....
212297	12485	Throat Plate, 50 needle hole, for needle sizes 14 and 15, for 212298 and 230402 .....
221183	12485	Throat Plate, 50 needle hole, for needle sizes 14 and 15, for 212285



## OBSOLETE PARTS

No.	Plate	Name
202470	12320	Bobbin Winder Base .....
202471	12320	“ “ Frame .....
202472	12319	“ “ “ Spring .....
202474	12320	“ “ Spindle .....
202480	12320	Bobbin Winder Spool Holder Base with 200355H and 202484 .....
202481	12320	Bobbin Winder Spool Holder Base Spool Pin .....
202482	12319	Bobbin Winder Spool Holder Ten- sion Disc (lower or upper) .....
202483	12319	Bobbin Winder Spool Holder Ten- sion Disc Spring (brass) .....
202484	12319	Bobbin Winder Spool Holder Ten- sion Disc Thread Guide .....
202485	12320	Bobbin Winder Spool Holder com- plete, Nos. 200011E, 202480, 202481, 202483, two 202482 and one wood screw 1 in., No. 13 .....
227522	12319	Bobbin Winder Stop Latch .....
202477	12319	“ “ Stop Latch Thumb Lever .....
227523	12320	Bobbin Winder complete, Nos. 200056E, 200161D, 200221D, 201537H, 202470 to 202474, 202477, 202478, 227523, three 200299H and two round head wood screws 1 in., No. 13 .....
212278	12177	Feed Dog, for 212276 and 212277 ..
212276	12177	Throat Plate, 50 needle hole, for needle sizes 14 and 15, for 212278
212277	12177	Throat Plate, 46 needle hole, for needle sizes 16 and 18, for 212278
212286	12486	Throat Plate, 50 needle hole, for needle sizes 14 and 15, for 212285
212287	12486	Throat Plate, 46 needle hole, for needle sizes 16 and 18, for 212285
215612	—	Vibrating Presser Bar .....
204489	13041	“ “ “ 215612 with 204493 and two 200138D .....
215628	—	Vibrating Presser Bar .....
204488	13041	“ “ “ 215628 with 204493 and two 200138D .....
204492	13041	Vibrating Presser Bar Position Guide .....

No.	Plate	Name
204623	13041	Vibrating Presser Foot, for 204488, 204602 and 204603 .....
204624	13041	Vibrating Presser Foot, for 204488, 204601 and 204607 .....
204625	13041	Vibrating Presser Foot, for 204488 and 204604 .....
204627	13041	Vibrating Presser Foot, for 204488 and 204609 .....
204630	13041	Vibrating Presser Foot, for 204602 and 204603 .....
204631	13041	Vibrating Presser Foot, for 204489 and 204604 .....
229632	13041	Vibrating Presser Foot, for 204488 and 204603 .....

PLATE 10445-FULL SIZE

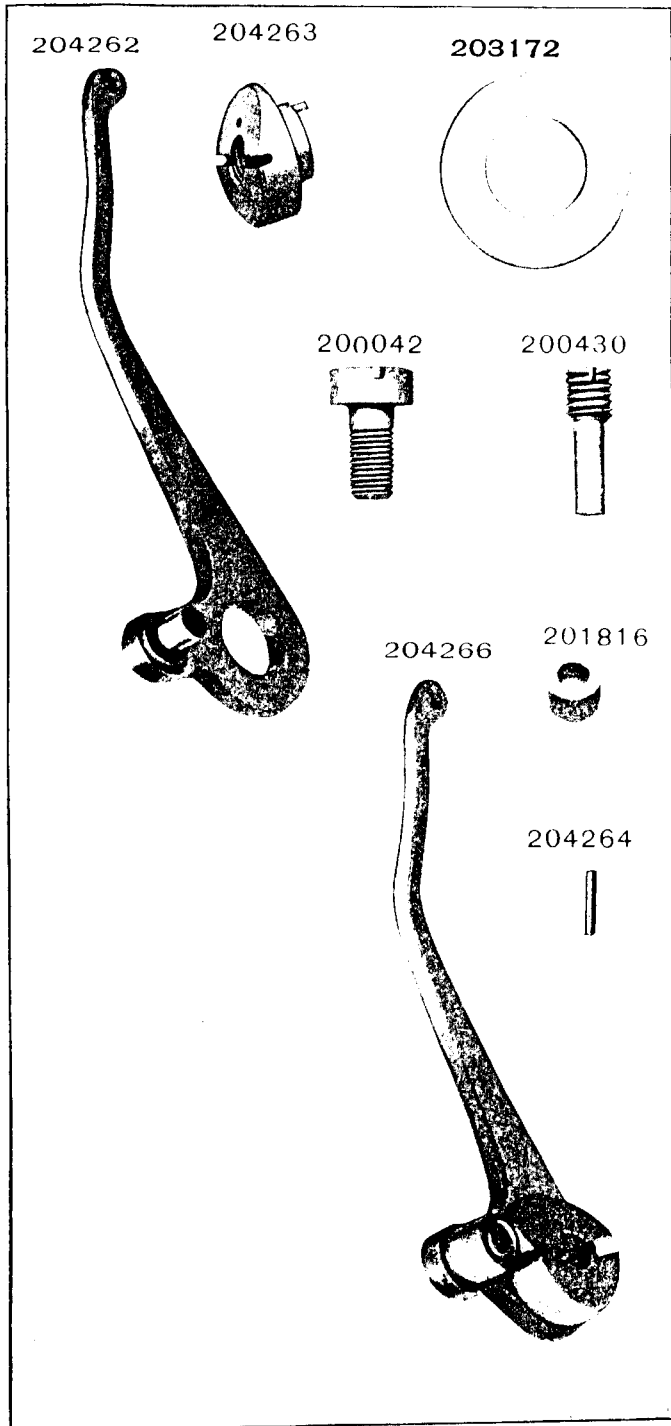
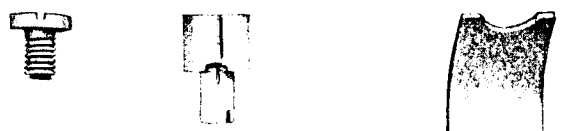
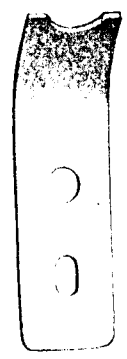
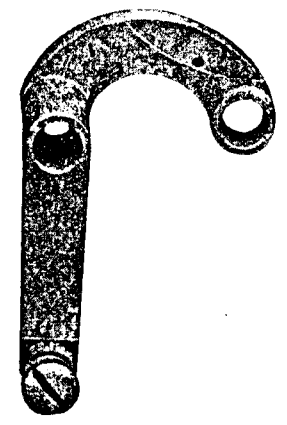


PLATE 10483—FULL SIZE

200181 202088 204486



204475



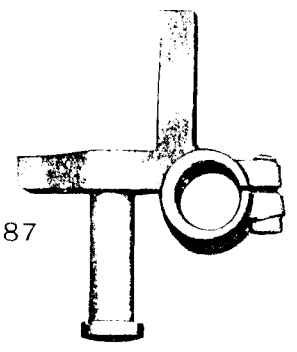
200309



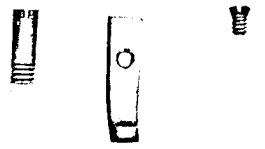
200122 200188



204480



200685 204487 200587

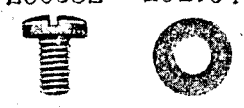
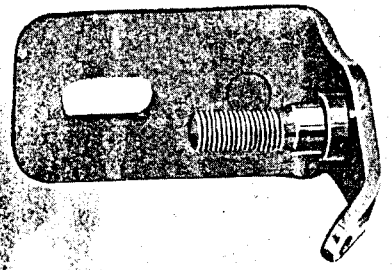


204478

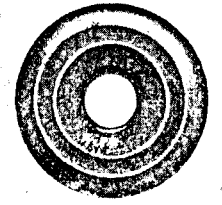


PLATE 10881—FULL SIZE

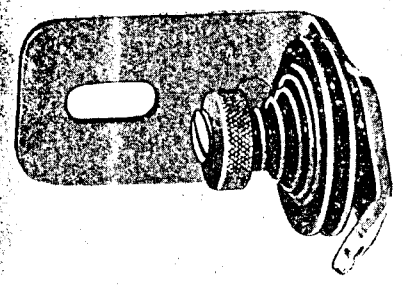
225461 200082 202104



2102



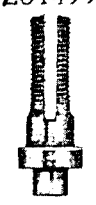
225462



202407



201499



201572



From the library of: Diamond Needle Corp



PLATE 10882—FULL SIZE

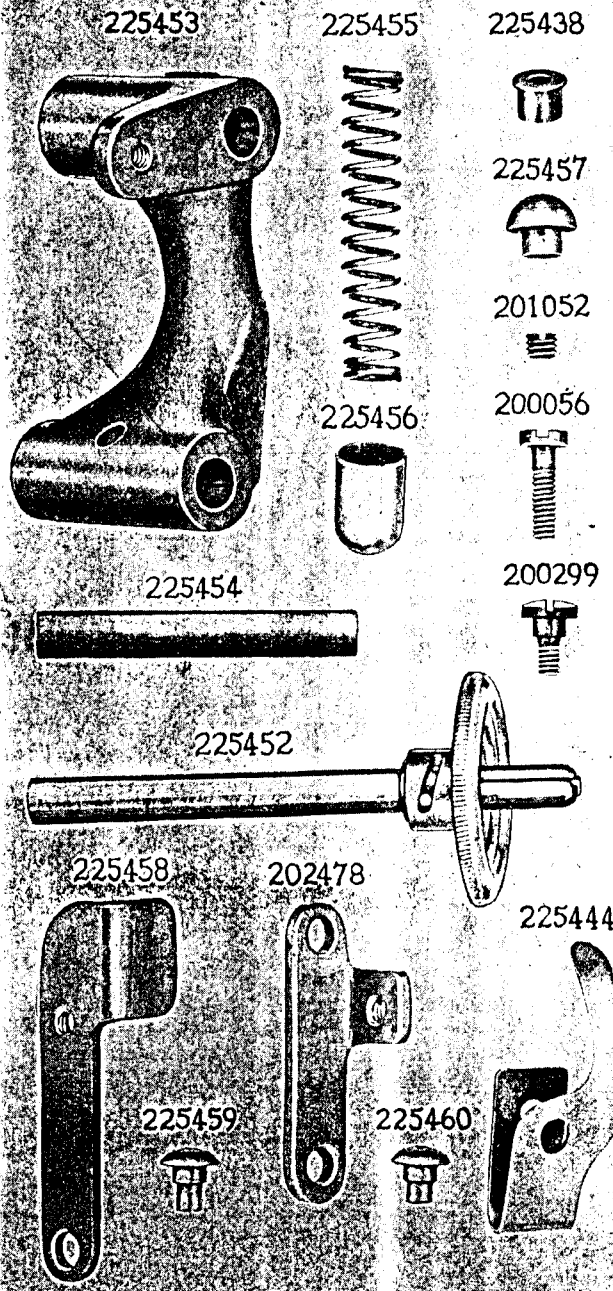
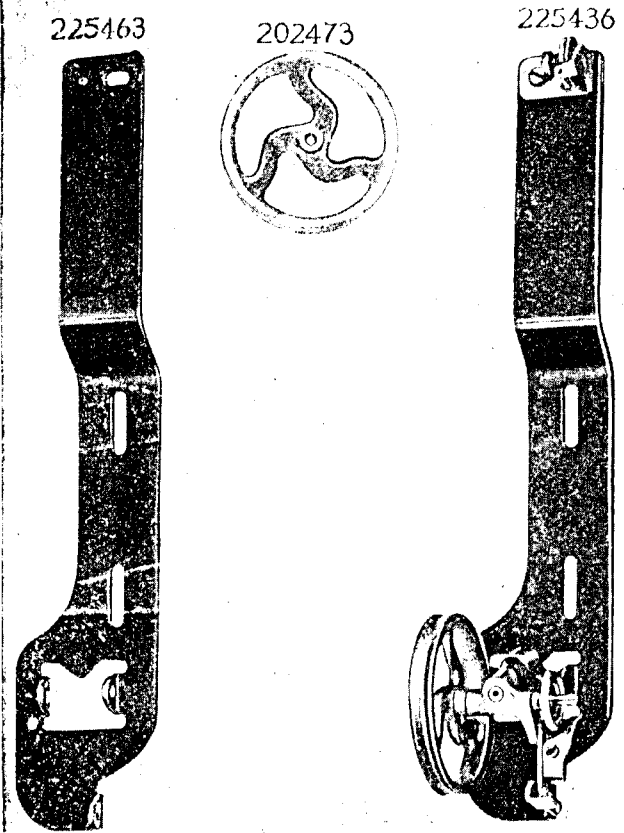


PLATE 10883—ONE-FOURTH SIZE



From the library of: Diamond Needle Corp

PLATE 11060-FULL SIZE

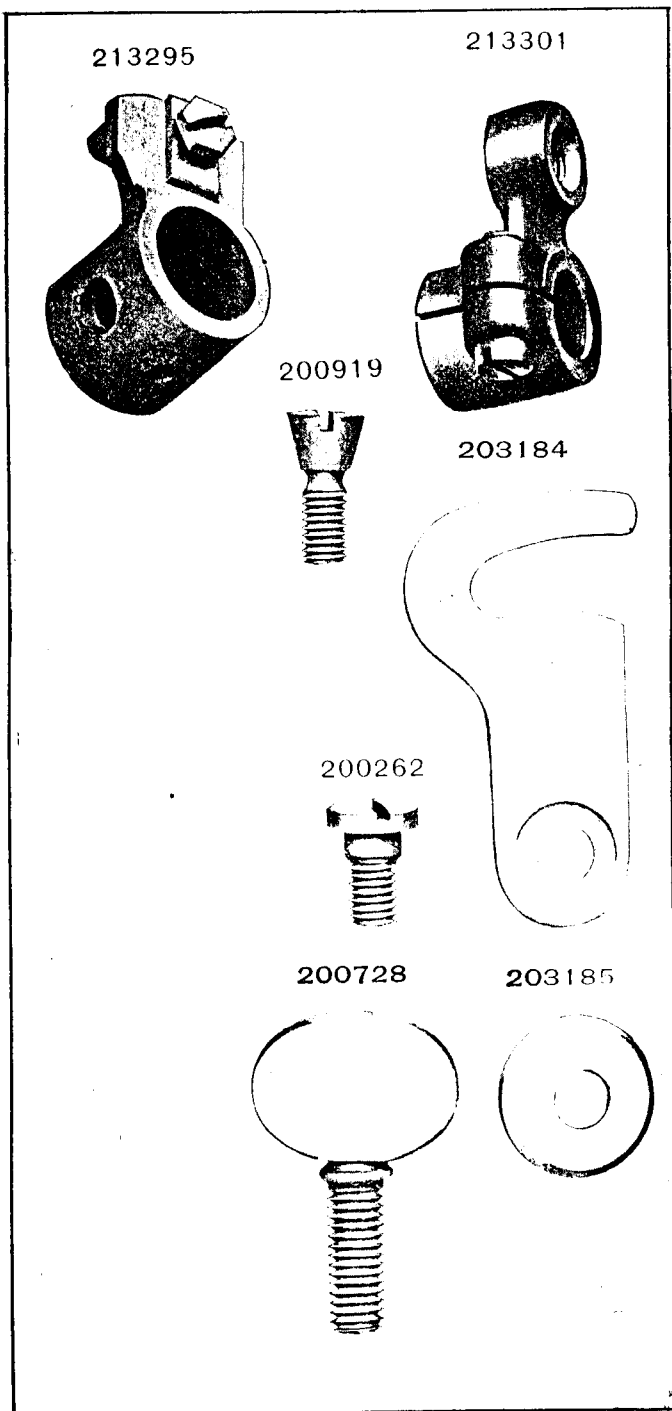
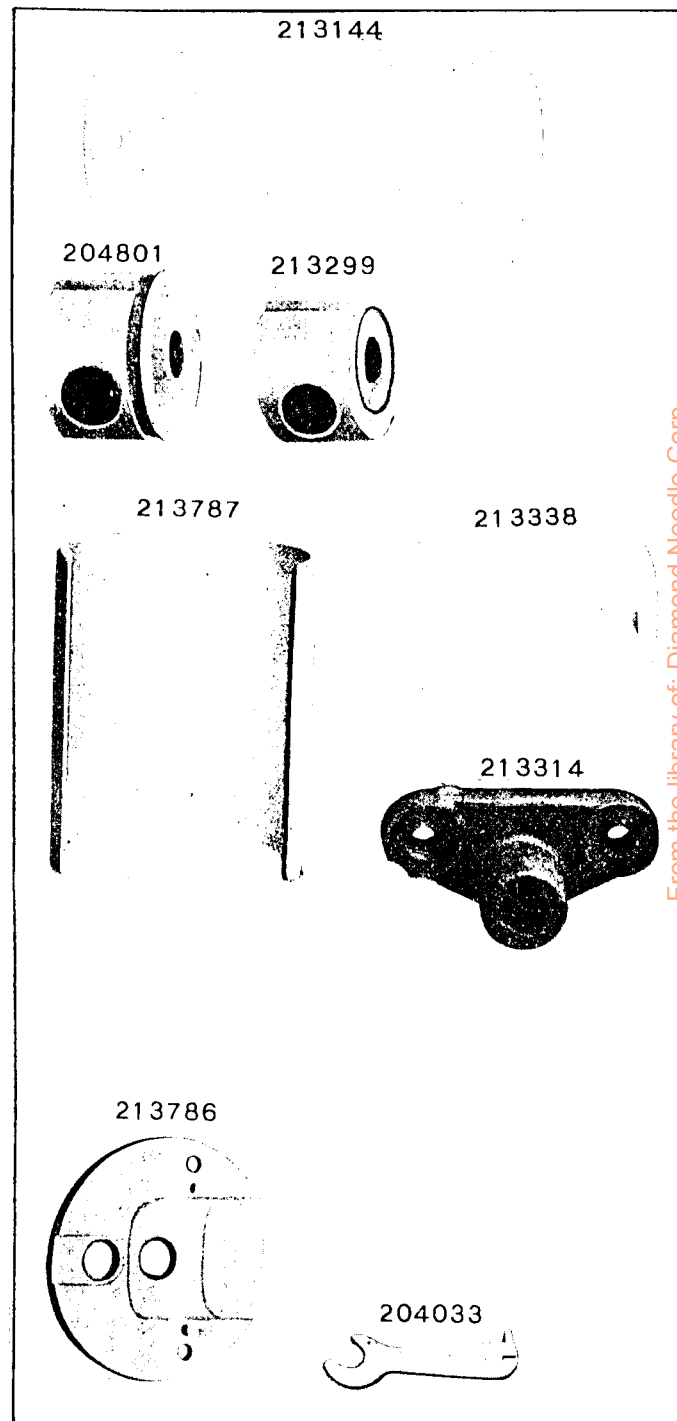


PLATE 11150 -ONE-HALF SIZE



From the library of: Diamond Needle Corp



PLATE 11151 - FULL SIZE

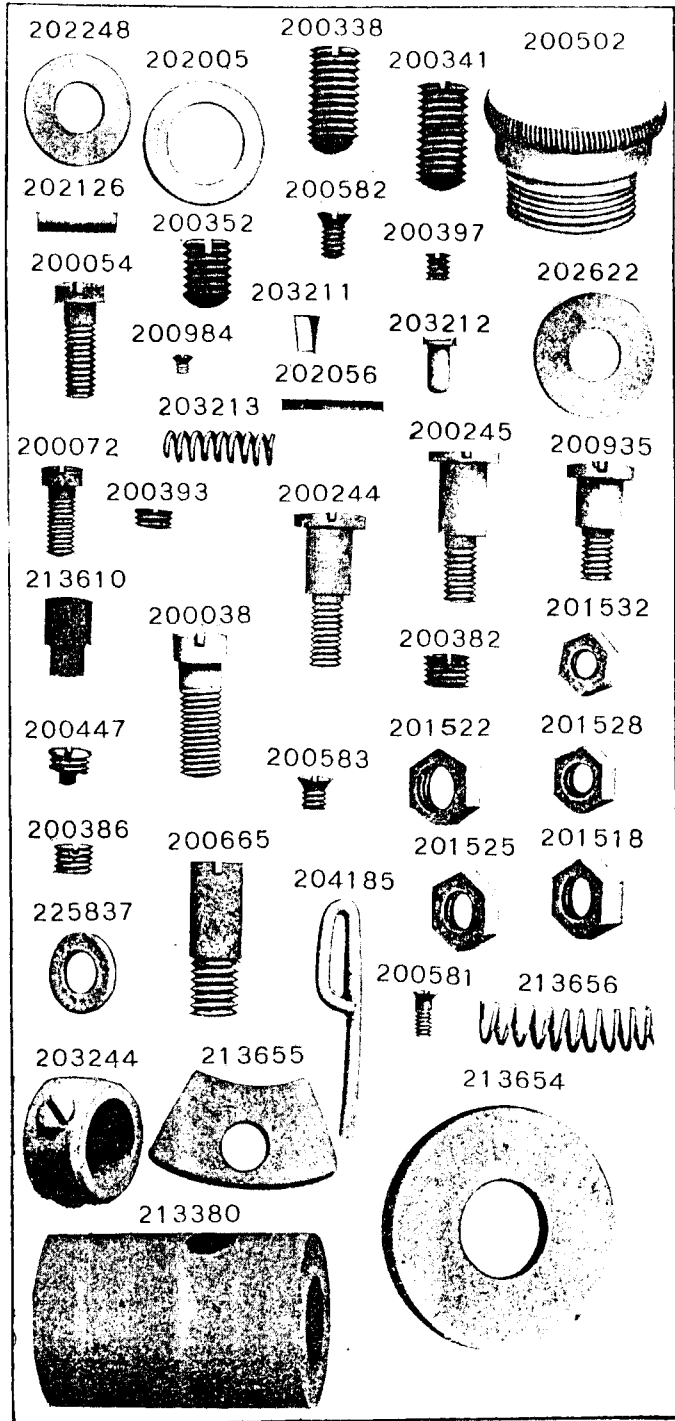
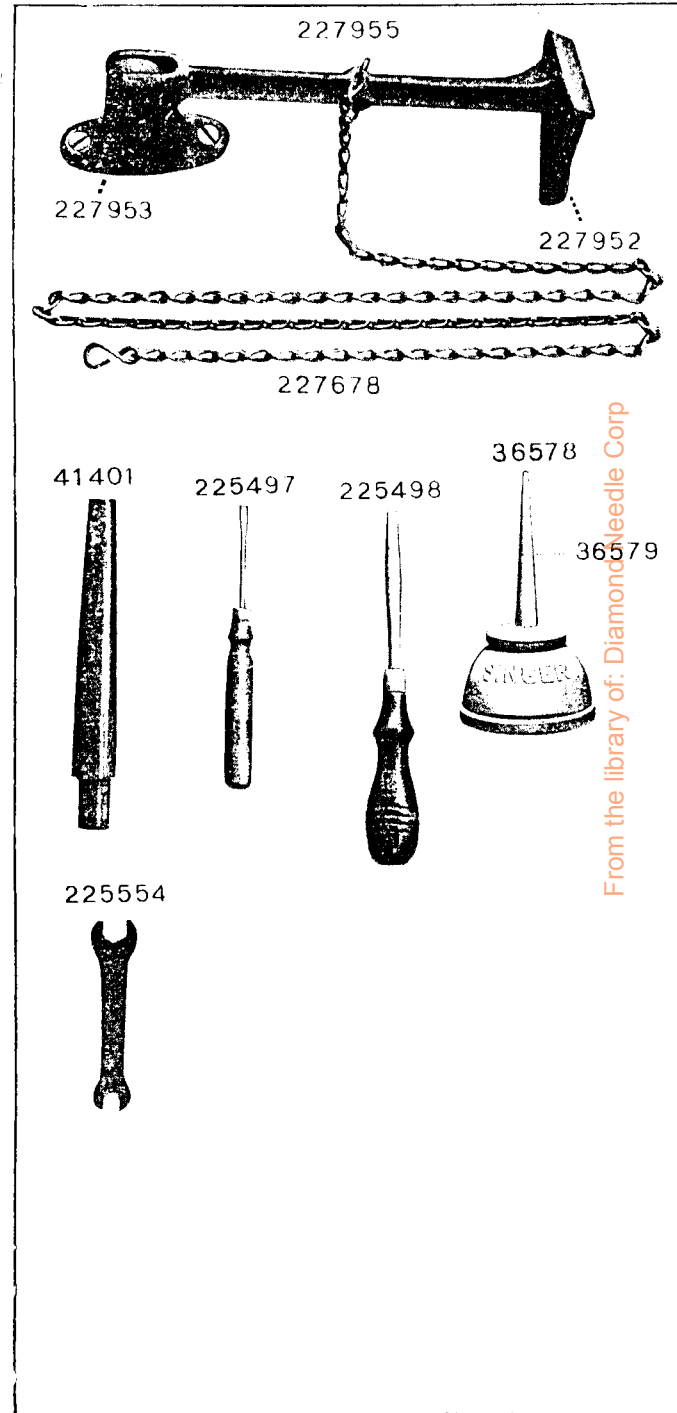


PLATE 11156 - ONE-FOURTH SIZE



From the library of: Diamond Needle Corp

PLATE 11161 - FULL SIZE

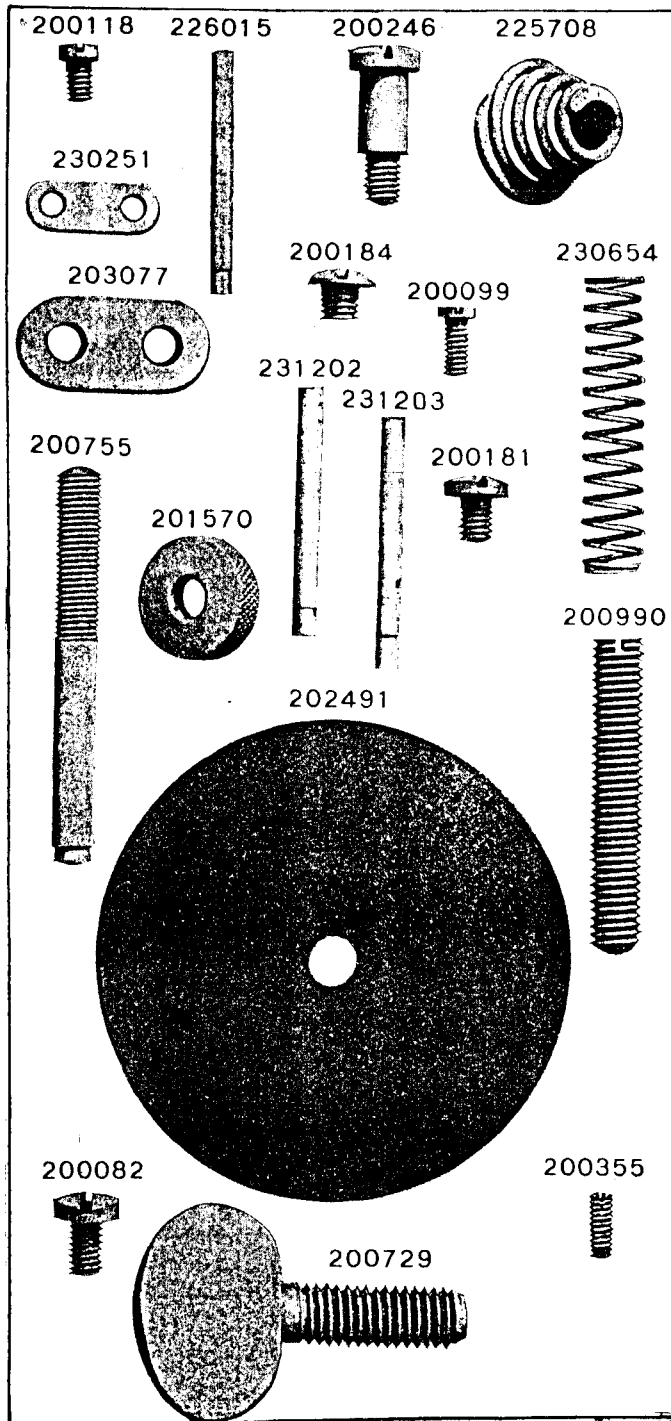
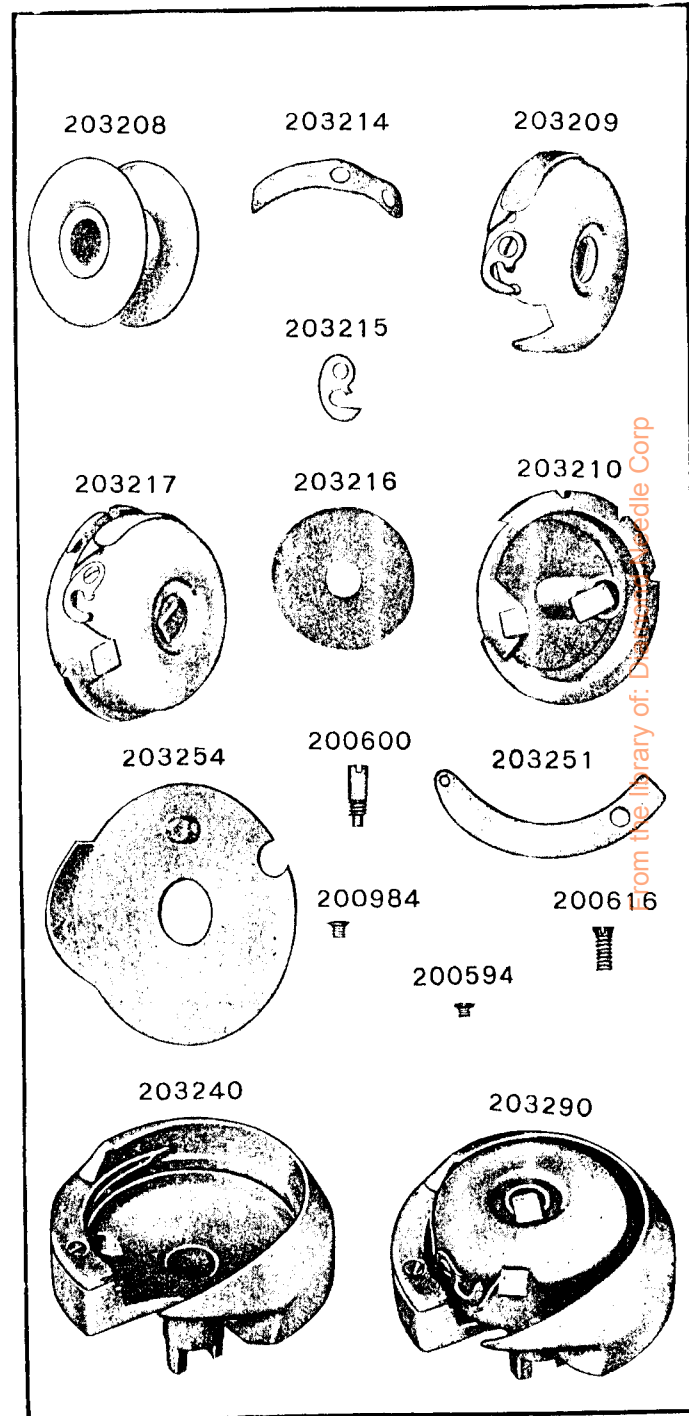


PLATE 11228 - FULL SIZE



From the library of: Dresser Needle Corp

PLATE 11254-ONE-HALF SIZE

203208



203209



203210



203549



203554

Nº 2 OUTFIT

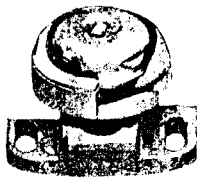
203240



203552



203554



203254



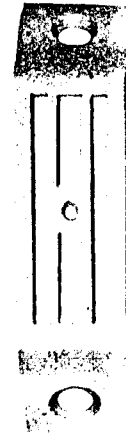
203254



PLATE 12177-FULL SIZE

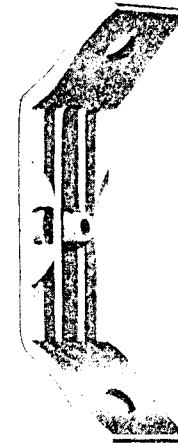
212276

212277



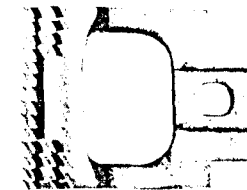
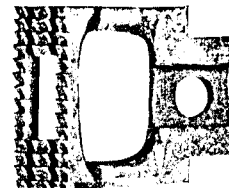
212276

212277



212278

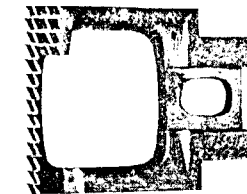
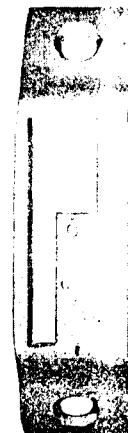
212278



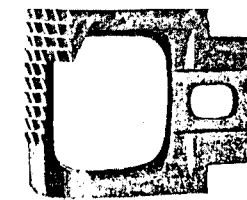
212279

212280

212281



212282



From the library of: Diamond Needle Corp

PLATE 12179—FULL SIZE

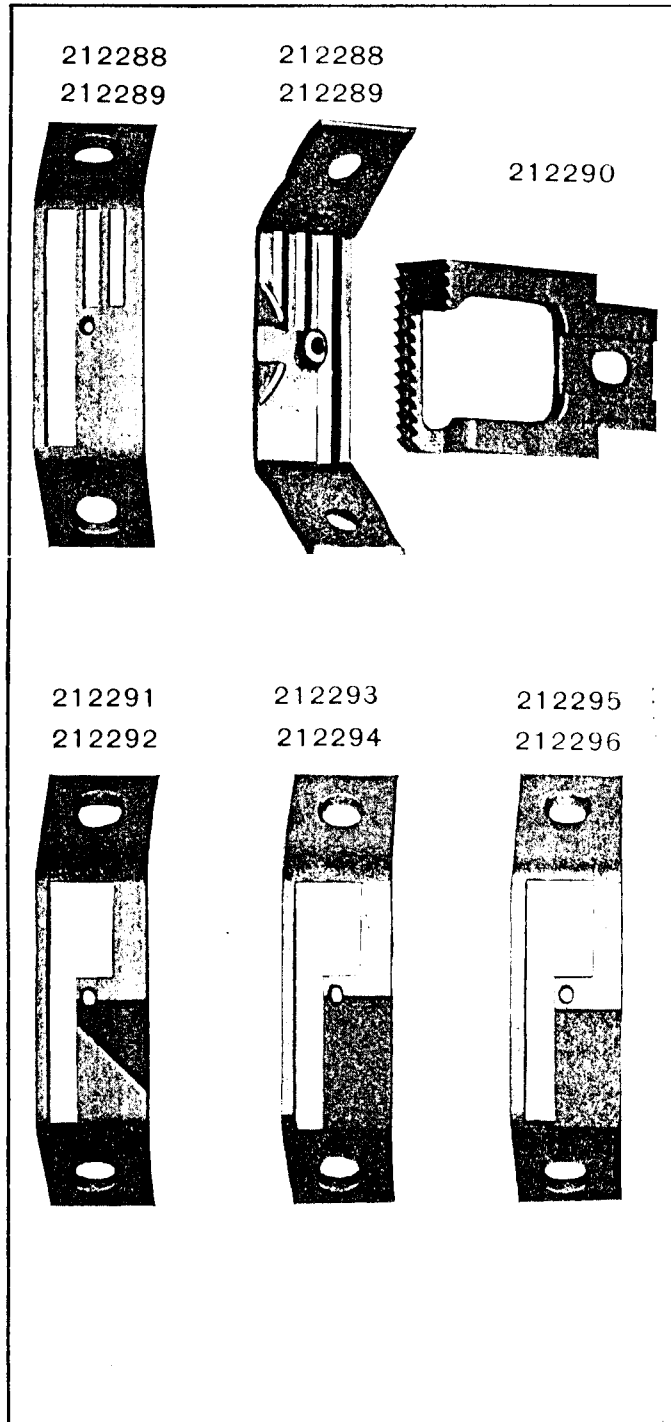
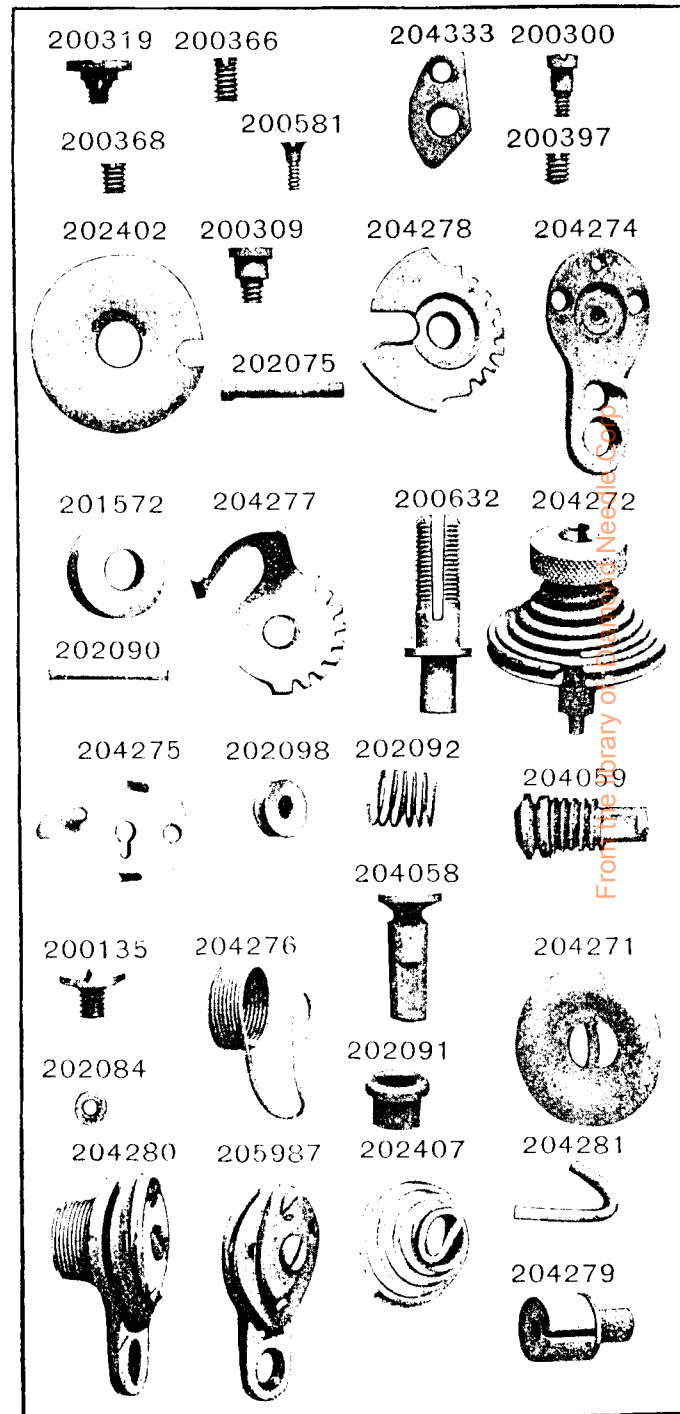


PLATE 12309—FULL SIZE



From the Library of the University of Illinois at Urbana-Champaign

PLATE 12311—FULL SIZE

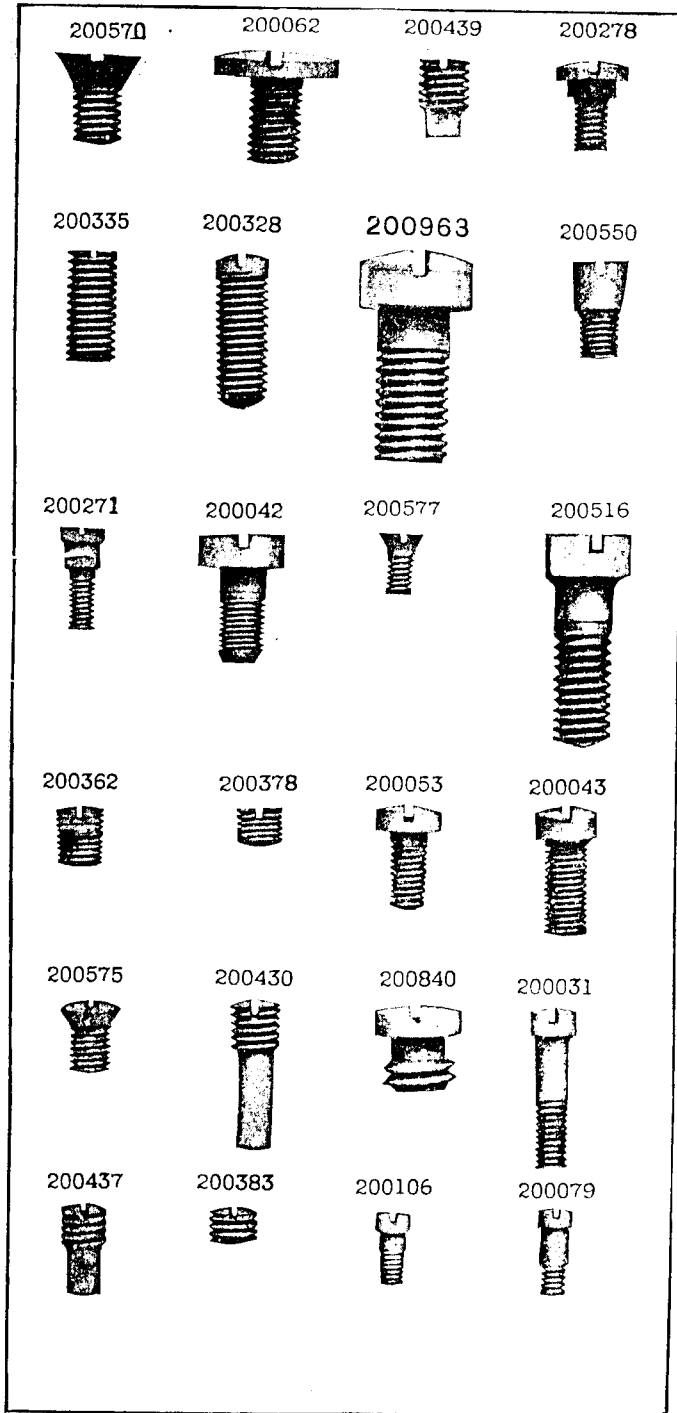
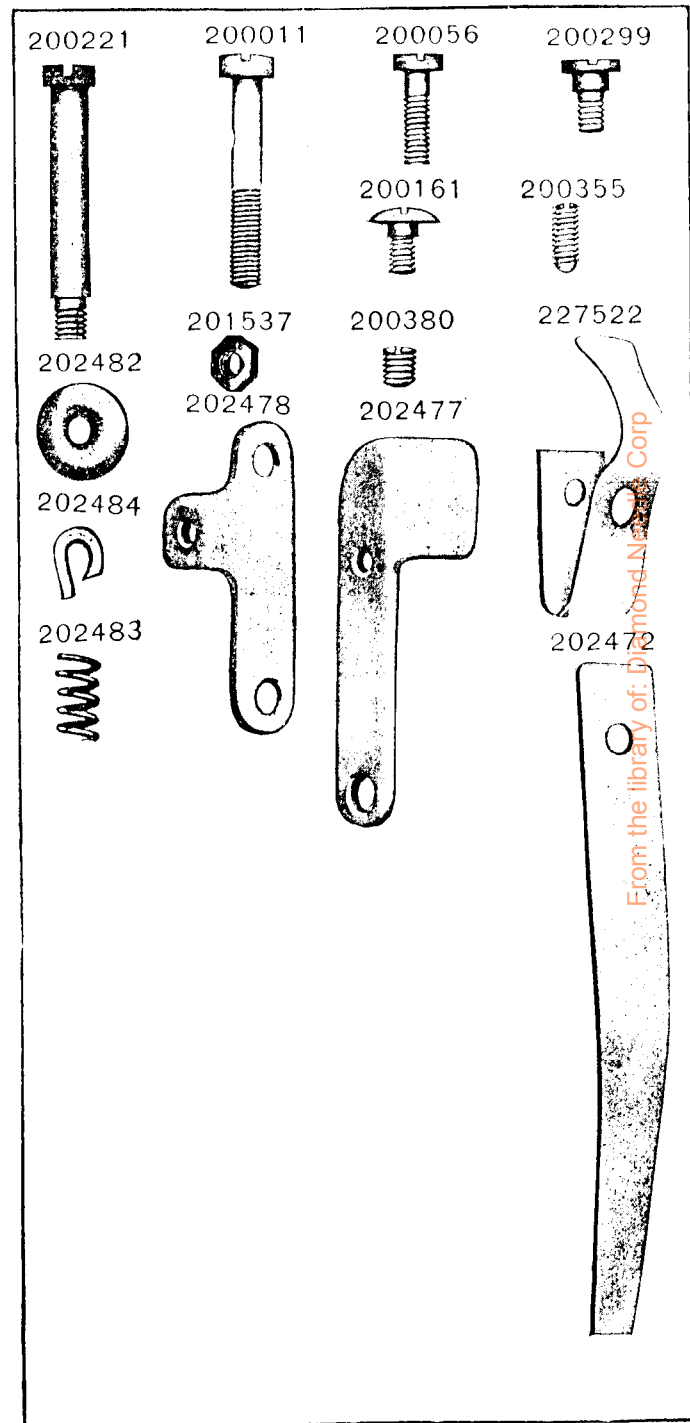


PLATE 12319 --FULL SIZE



From the library of: Diamond-Nippon Corp

PLATE 12320—ONE-HALF SIZE

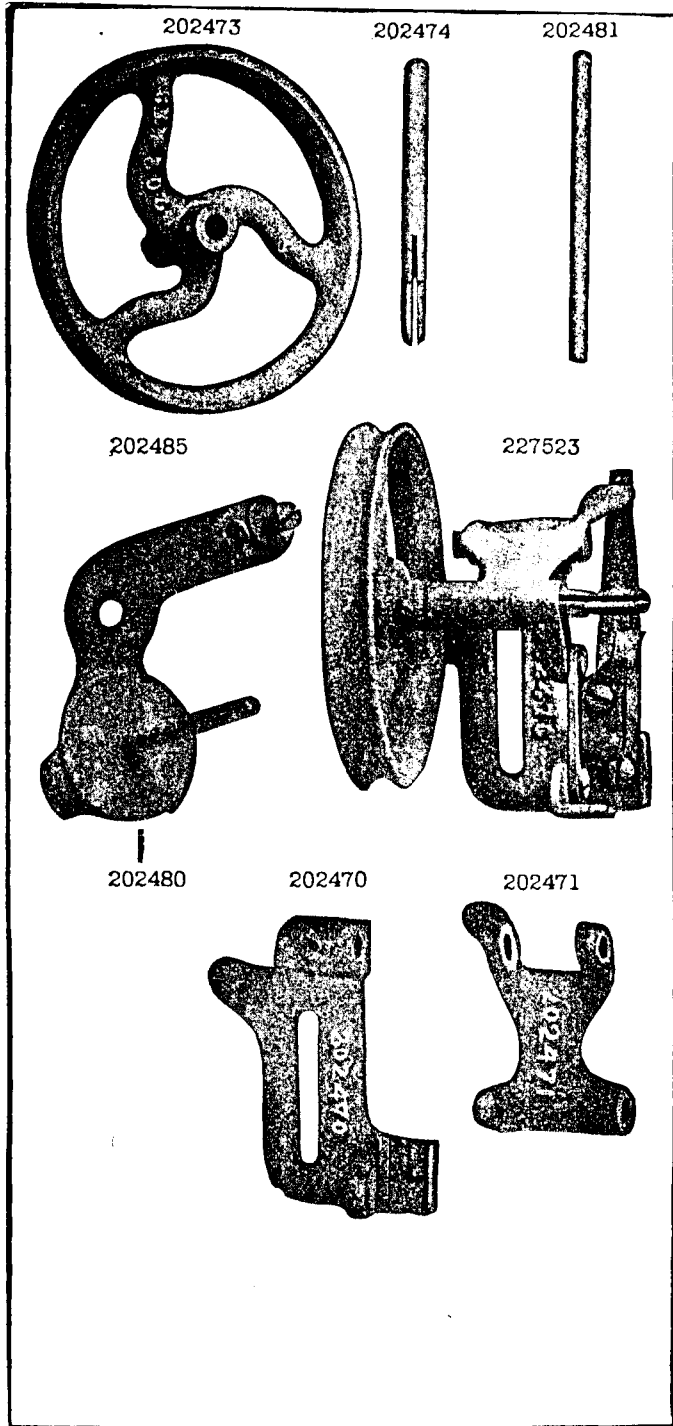
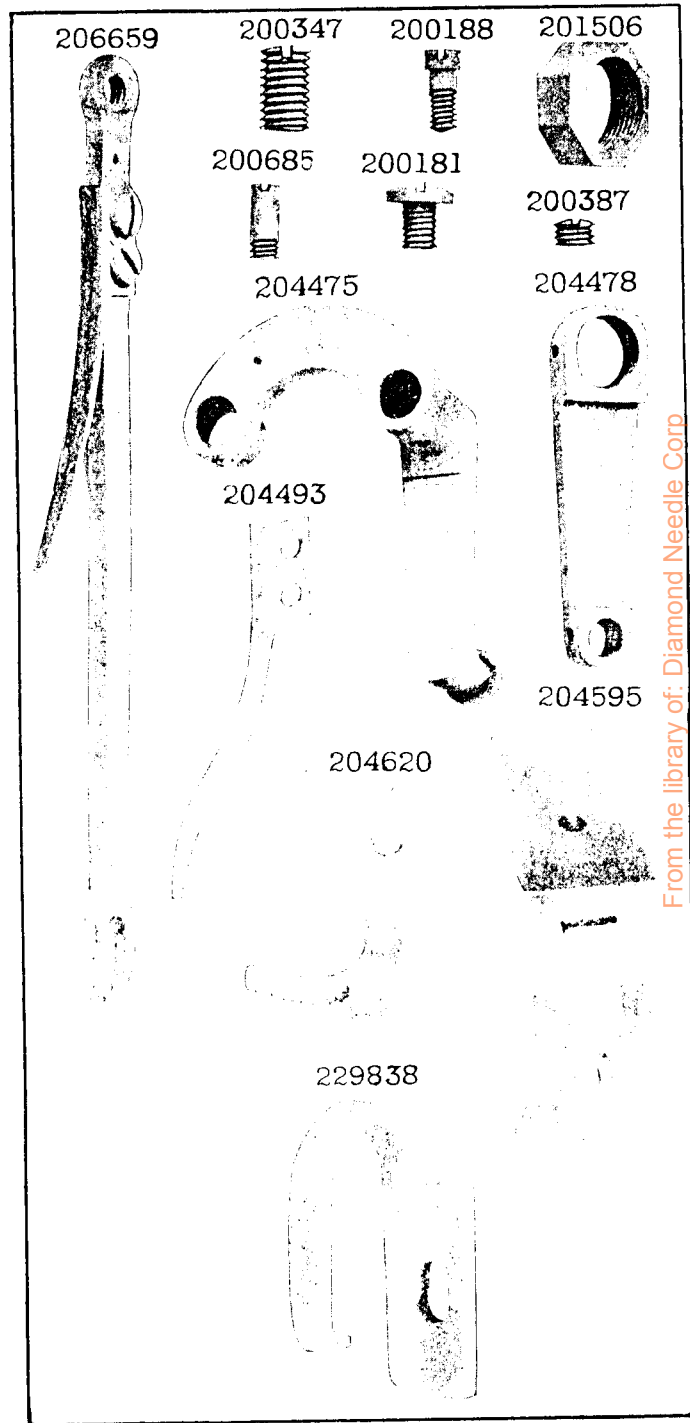


PLATE 12376—FULL SIZE



From the library of: Diamond Needle Corp



PLATE 12473-FULL SIZE

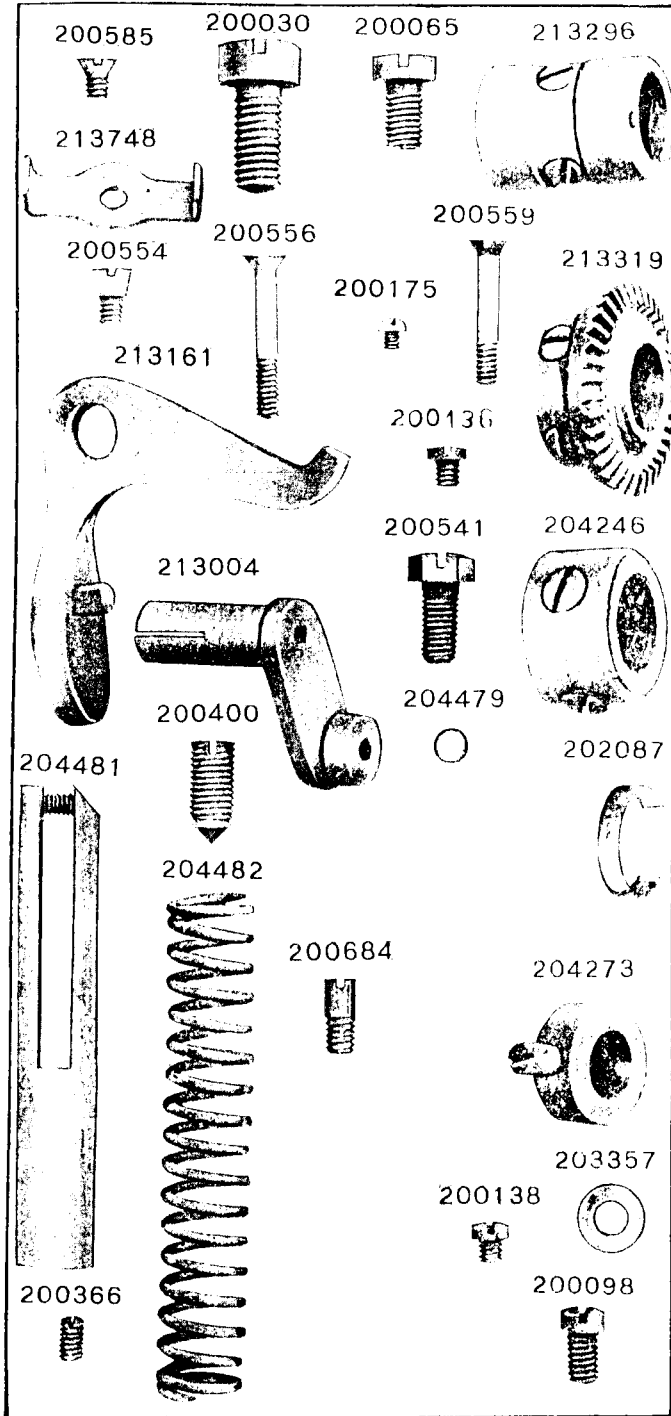
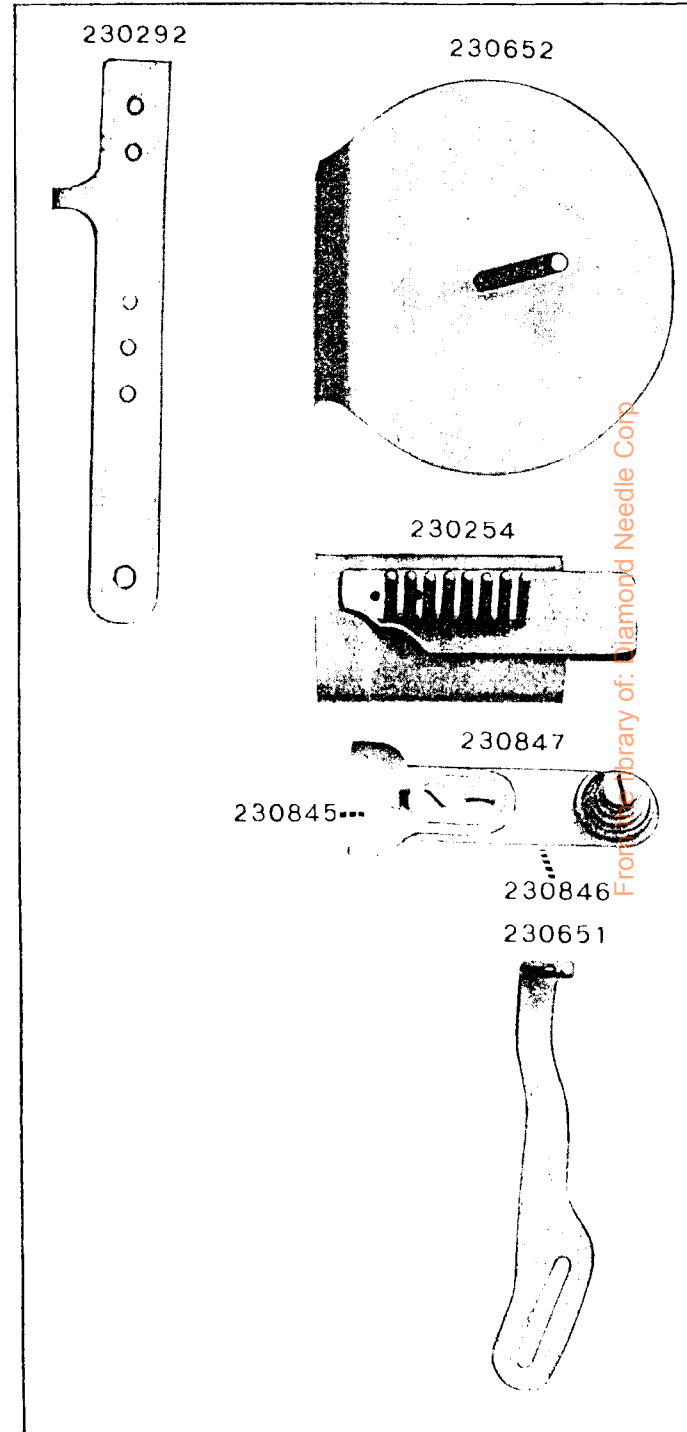


PLATE 12480-ONE-HALF SIZE



From Library of: Diamond Needle Corp

PLATE 12481—FULL SIZE

221145

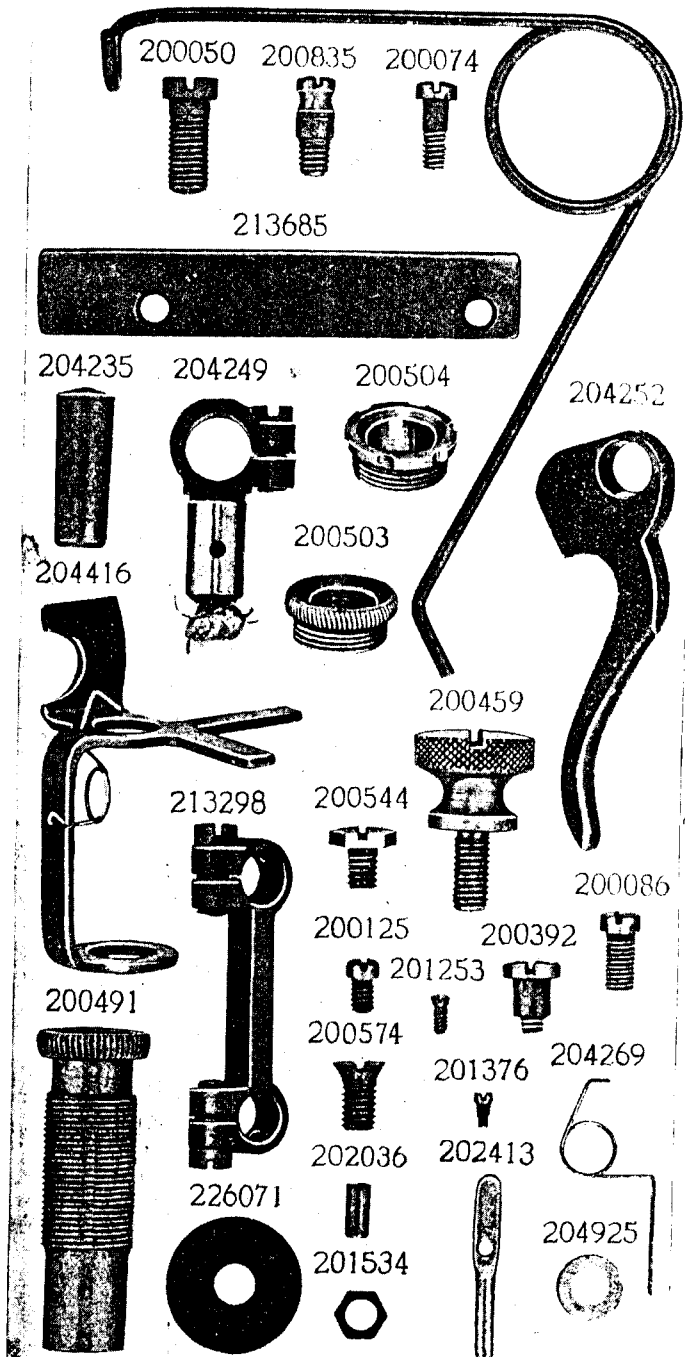
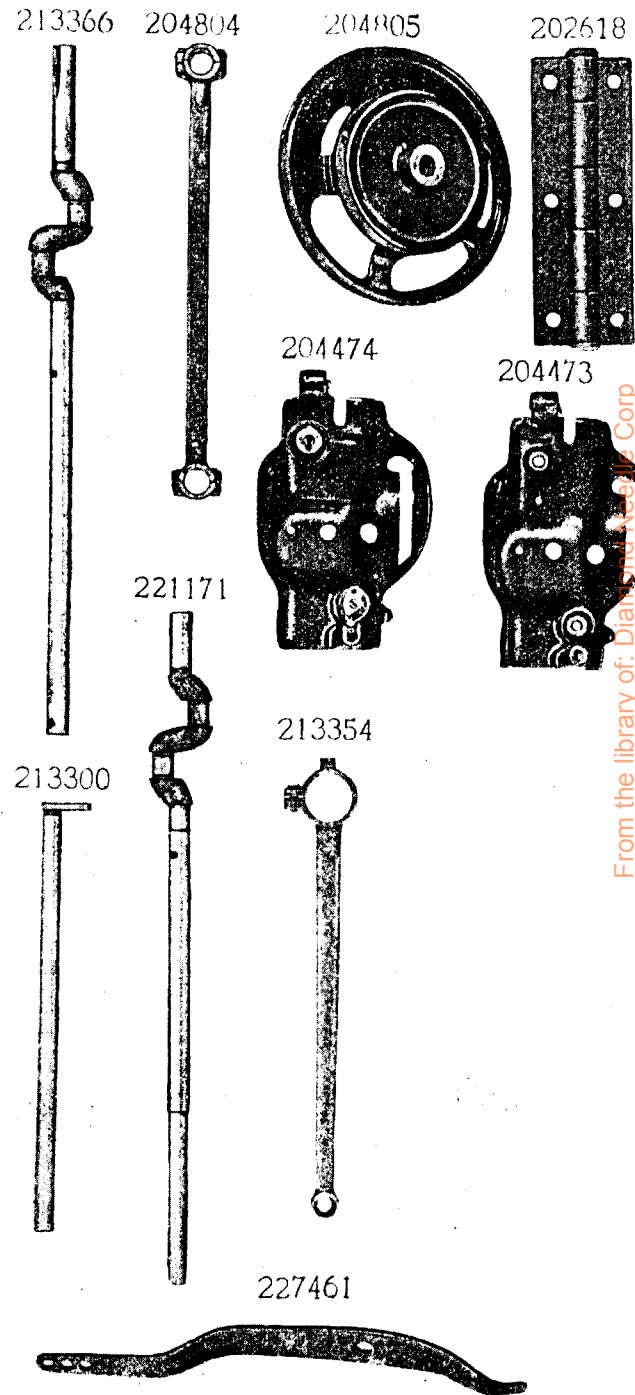


PLATE 12482—ONE-FOURTH SIZE



From the library of: [Dial and Valve Corp](#)



PLATE 12483—ONE-HALF SIZE

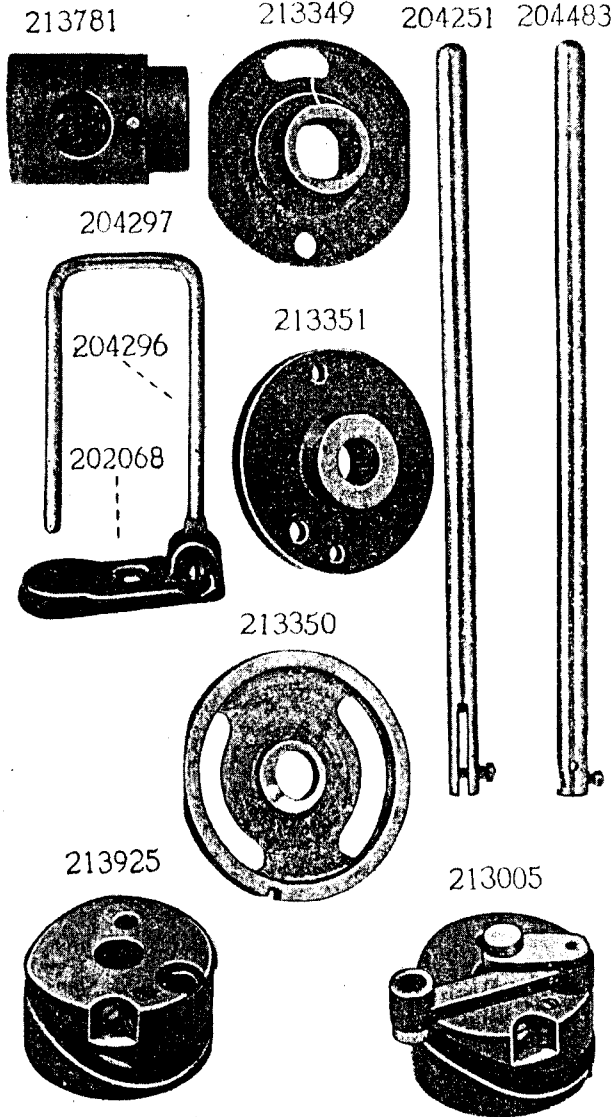
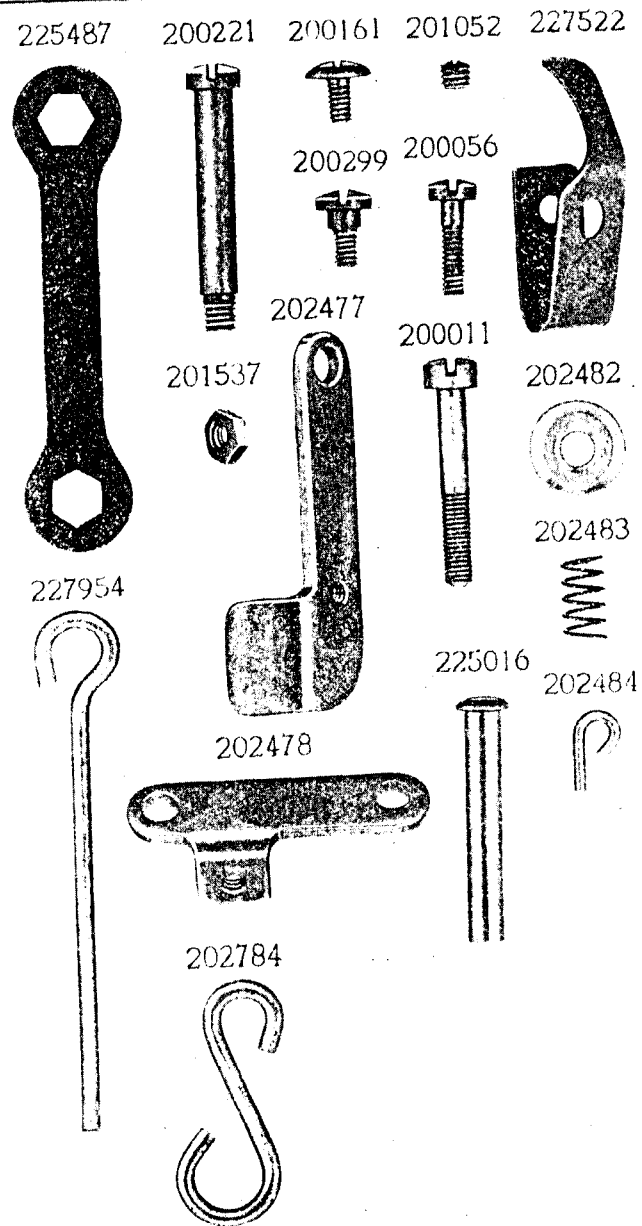


PLATE 12484—FULL SIZE



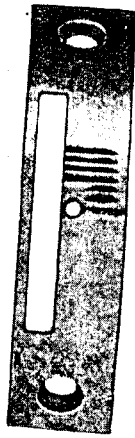
From the library of: Diamond Needle Corp

PLATE 12485-FULL SIZE

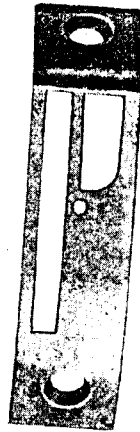
212256  
212257



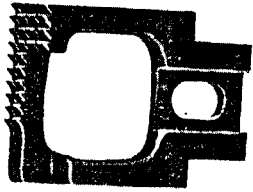
212297



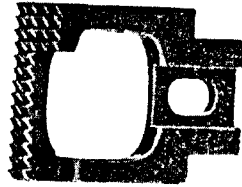
221183



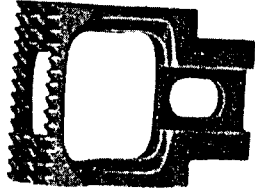
212220



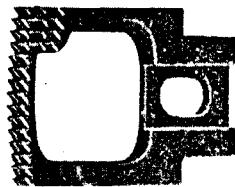
212221



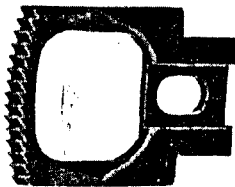
212258



212285



212298



212316

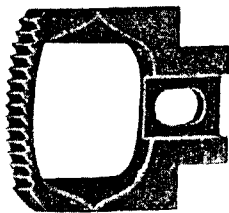


PLATE 12486-FULL SIZE

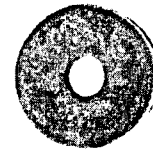
200925



201526



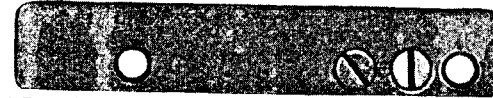
230294



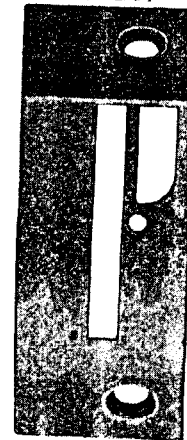
230293



230648



212286  
212287



200469



200137



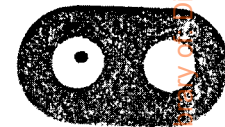
230649



212302



225689



From the library of [www.amor.com](http://www.amor.com)

PLATE 13034—FULL SIZE

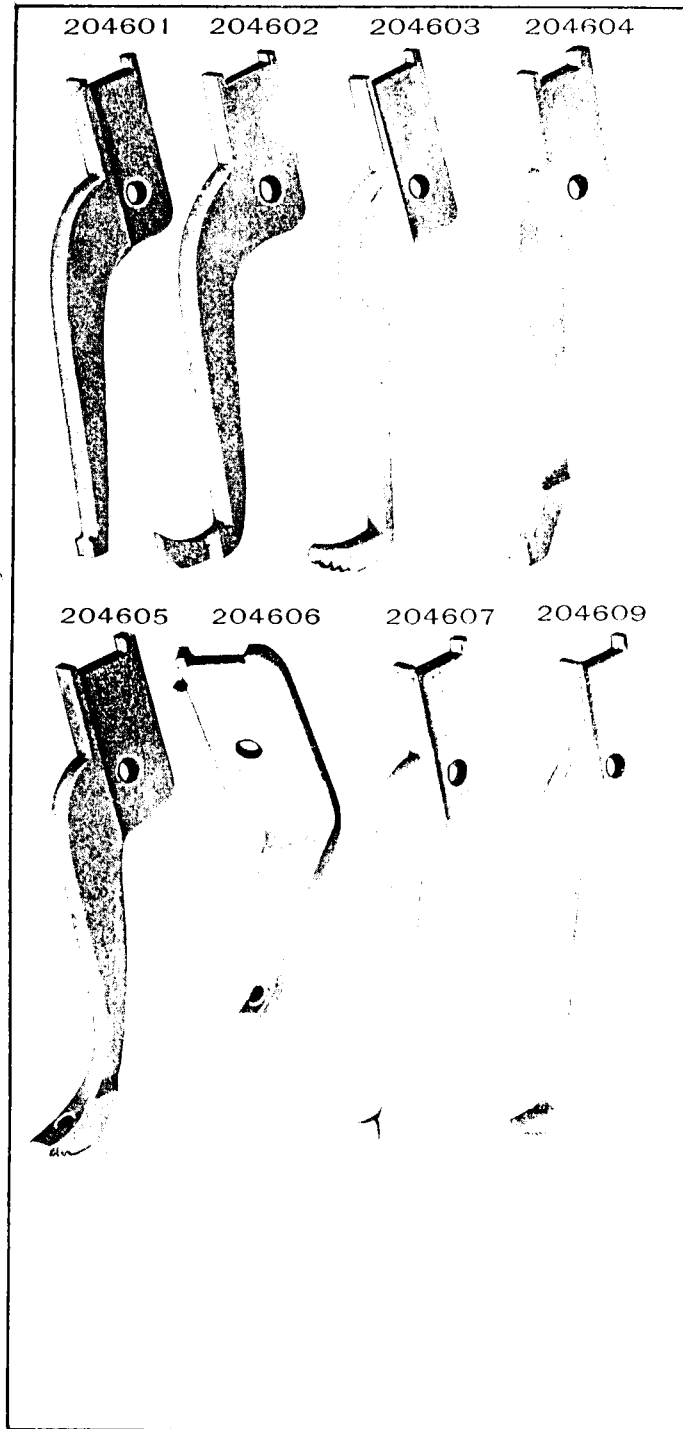
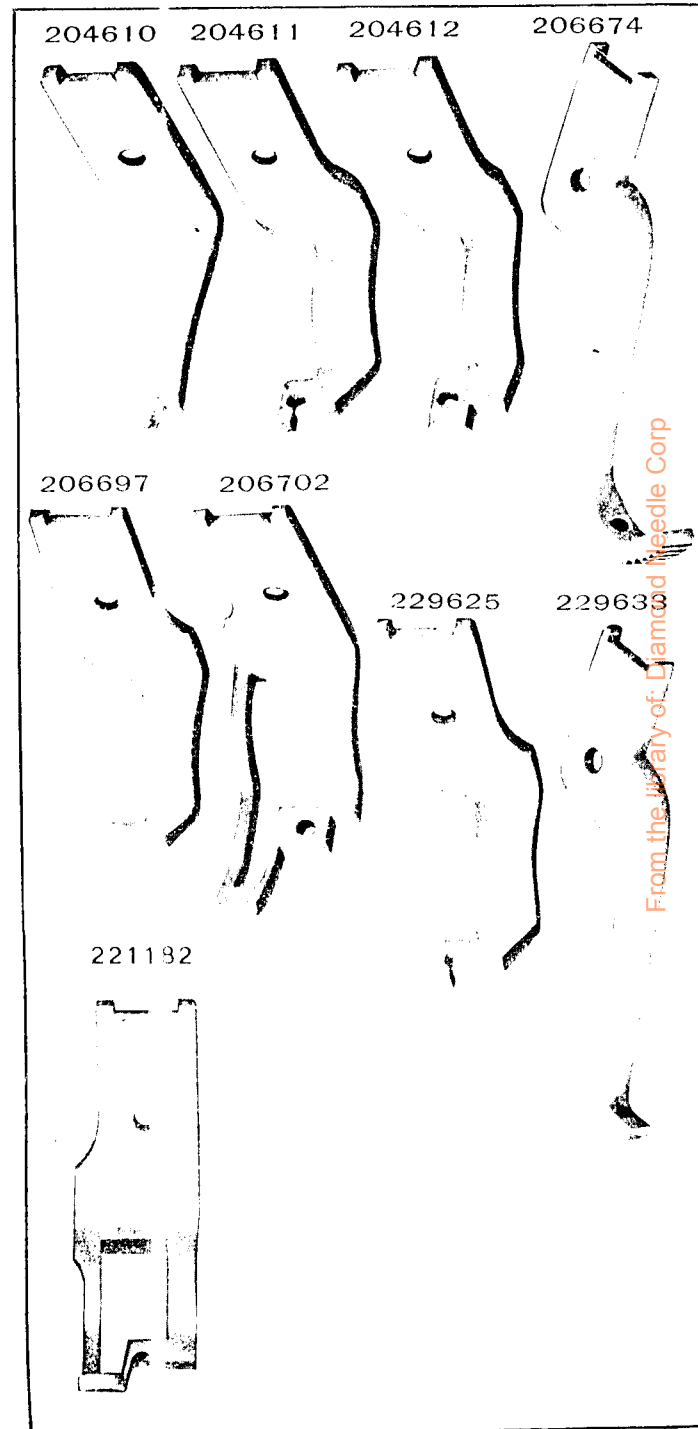


PLATE 13035—FULL SIZE



From the library of Diamond Needle Corp

PLATE 13036-FULL SIZE

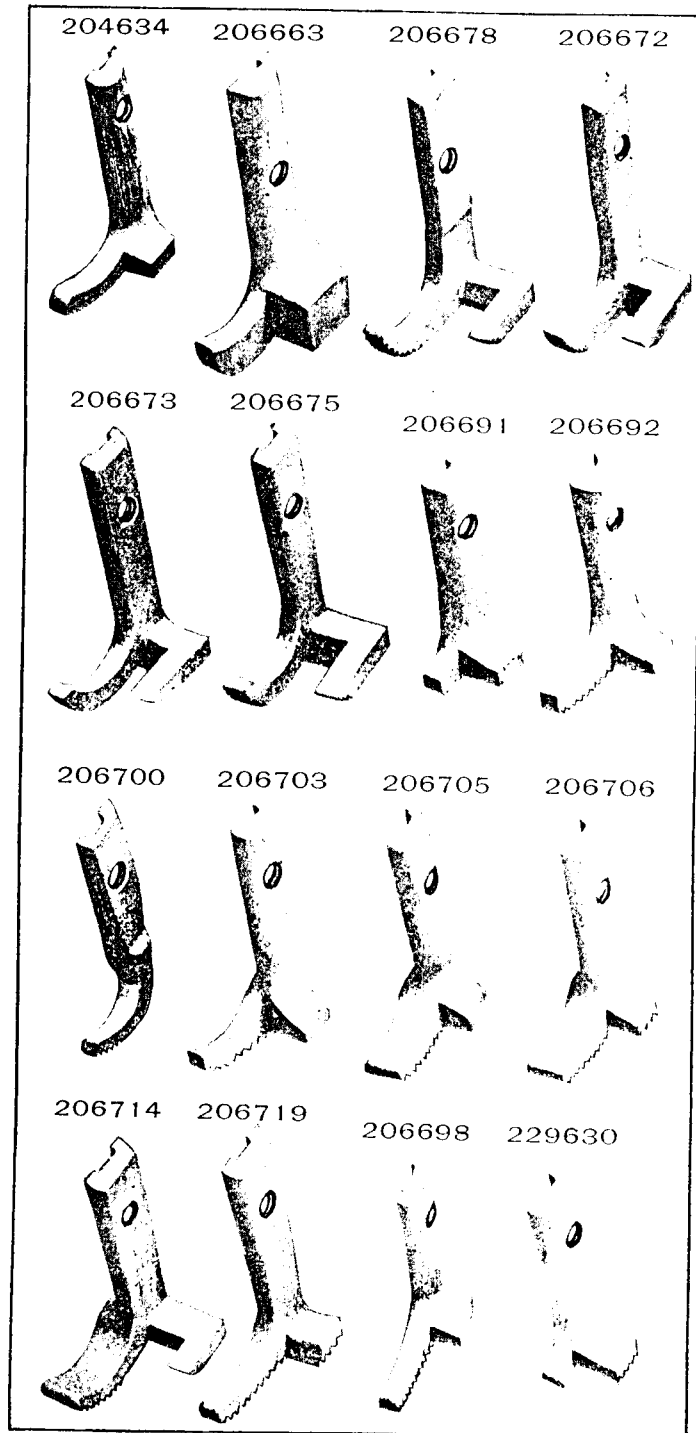


PLATE 13037-FULL SIZE

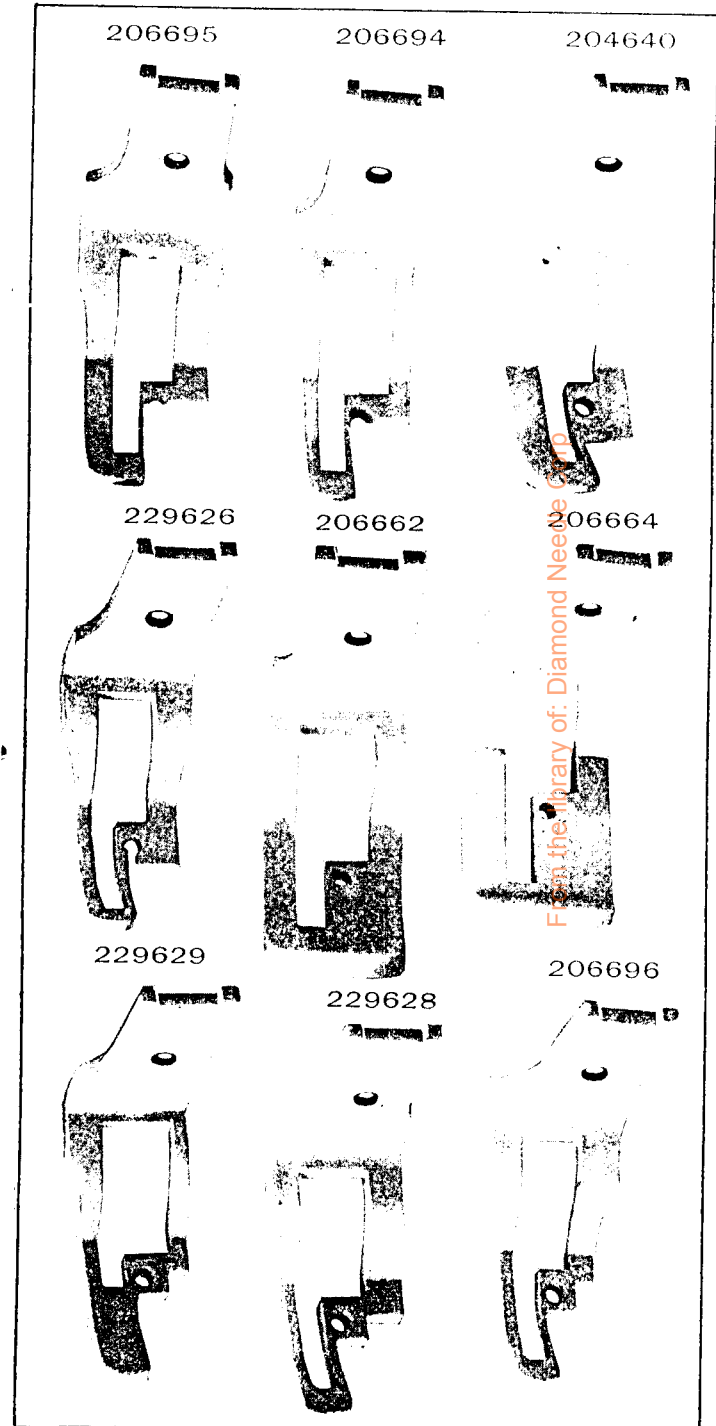


PLATE 13038—FULL SIZE

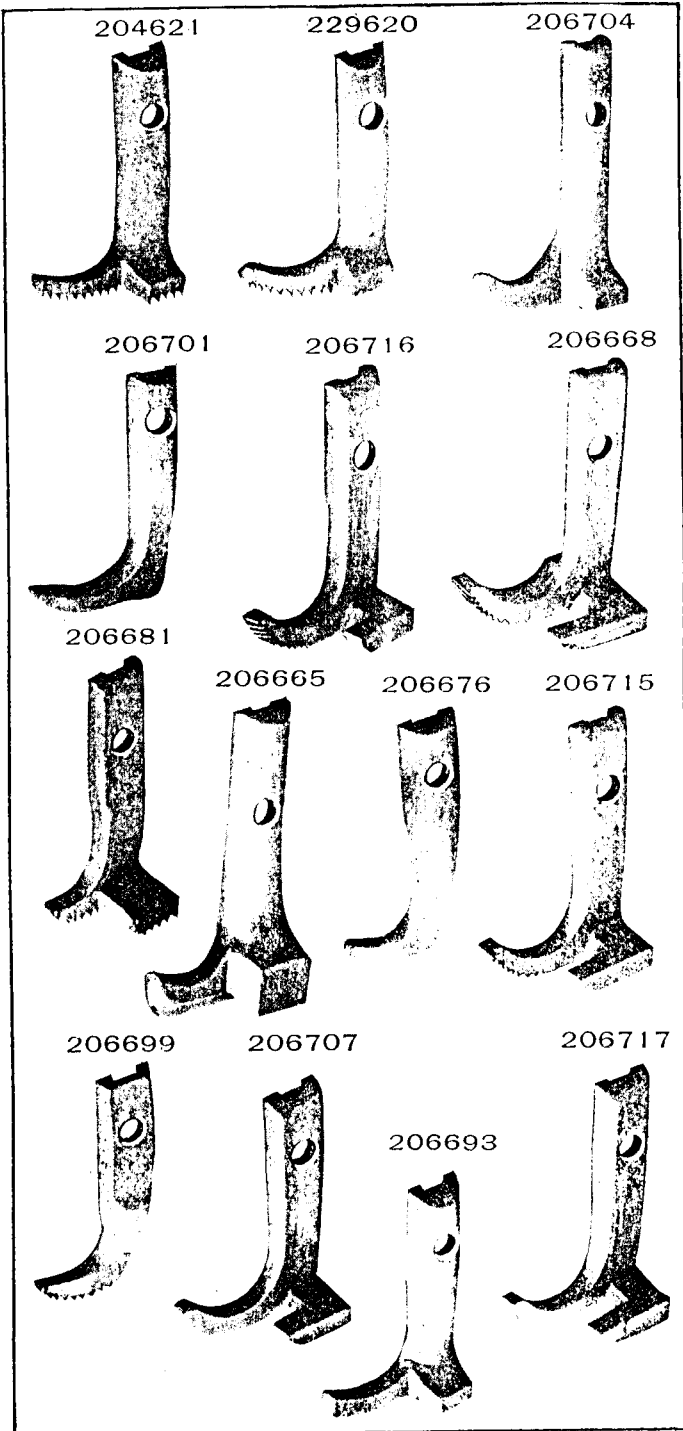


PLATE 13041—FULL SIZE

